



website <http://www.lgservice.com>

LG

# LG Room Air Conditioner

## ***SERVICE MANUAL***

**MODELS: HBLG1803R  
HBLG1453E  
L1804R  
LW1400ER  
LW180CE**

### **CAUTION**

- BEFORE SERVICING THE UNIT, READ THE SAFETY PRECAUTIONS IN THIS MANUAL.
- ONLY FOR AUTHORIZED SERVICE PERSONNEL.

# TABLE OF CONTENTS

|  |    |
|--|----|
| <b>Safety Precautions</b> .....              | 3  |
| <b>Dimensions</b> .....                      | 5  |
| Outside dimensions .....                     | 5  |
| <b>Product Specifications</b> .....          | 6  |
| <b>Installation</b> .....                    | 7  |
| Select the Best Location .....               | 7  |
| Installation Check .....                     | 7  |
| How to Secure the Drain Pipe .....           | 7  |
| How to Install .....                         | 8  |
| Cabinet Installation .....                   | 9  |
| <b>Operation</b> .....                       | 11 |
| Function of Controls .....                   | 11 |
| <b>Disassembly</b> .....                     | 12 |
| Mechanical Parts .....                       | 12 |
| Air Handling Parts .....                     | 13 |
| Electrical Parts .....                       | 14 |
| Refrigerating Cycle .....                    | 16 |
| <b>Schematic Diagram</b> .....               | 19 |
| Electronic Control Device .....              | 19 |
| Wiring Diagram .....                         | 20 |
| Components Location .....                    | 21 |
| <b>Troubleshooting Guide</b> .....           | 22 |
| Piping System .....                          | 22 |
| Troubleshooting Guide .....                  | 23 |
| Electrical Parts Troubleshooting Guide ..... | 25 |
| Electric Parts .....                         | 29 |
| <b>Exploded View</b> .....                   | 35 |
| <b>Replacement Parts List</b> .....          | 36 |

# Safety Precautions

To prevent injury to the user or other people and property damage, the following instructions must be followed.

■ Incorrect operation due to ignoring instruction will cause harm or damage. The seriousness is classified by the following indications.

**⚠ WARNING** This symbol indicates the possibility of death or serious injury.

**⚠ CAUTION** This symbol indicates the possibility of injury or damage to properties only.

■ Meanings of symbols used in this manual are as shown below.

|  |   |
|--|---|
|  | <b>Be sure not to do.</b>                 |
|  | <b>Be sure to follow the instruction.</b> |

## ⚠ WARNING

### ■ Installation

**Do not use damaged power cord plugs, or a loose socket.**

- There is risk of fire or electric shock.

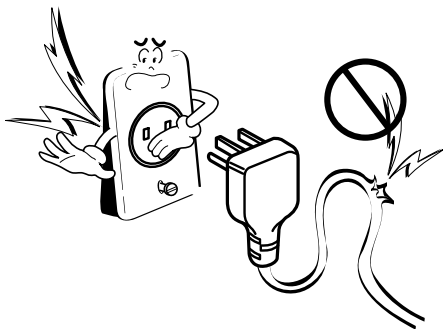

**Always use the power plug and socket with the ground terminal.**

- There is risk of electric shock.

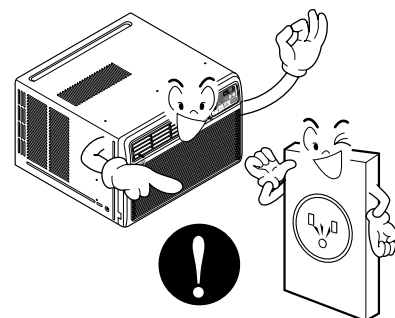

**Do not modify or extend the power cord.**

- There is risk of fire or electric shock.

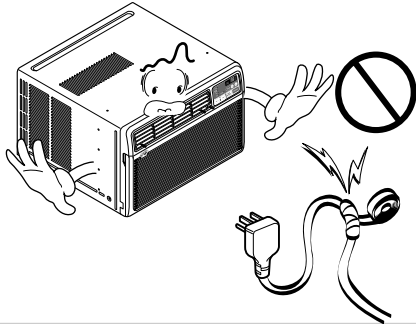

**Be cautious when unpacking and installing the product.**

- Sharp edges could cause injury. Be especially careful of the case edges and the fins on the condenser and evaporator.

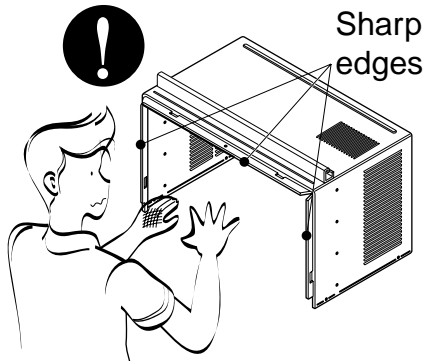

**Do not install, remove, or re-install the unit by yourself(customer).**

- There is risk of fire, electric shock, explosion, or injury.

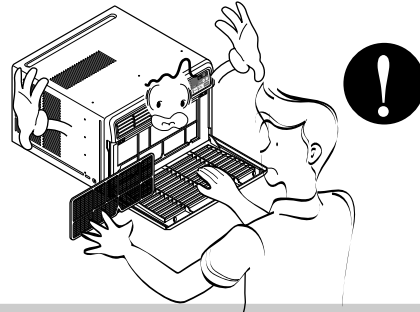

**Do not store or use flammable gas or combustibles near the air conditioner.**

- There is risk of fire or failure of product.

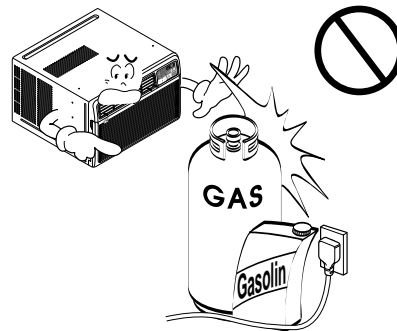

**Be sure the installation area does not deteriorate with age.**

- If the base collapses, the air conditioner could fall with it, causing property damage, product failure, and personal injury.

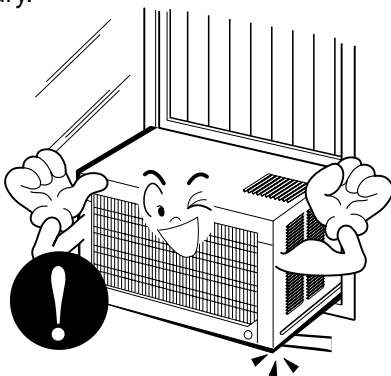

# Dimensions

## Symbols Used in this Manual



This symbol alerts you to the risk of electric shock.



This symbol alerts you to hazards that could cause harm to the air conditioner.

**NOTICE**

This symbol indicates special notes.

## Outside Dimensions

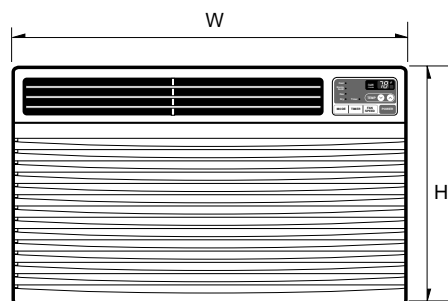
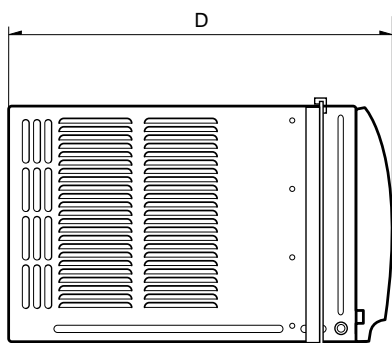

| Model     |          | ALL MODELS                             |
|-----------|----------|--|
| Dimension |          |  |
| W         | mm(inch) | 660(25 <sup>31</sup> / <sub>32</sub> ) |
| H         | mm(inch) | 428(16 <sup>27</sup> / <sub>32</sub> ) |
| D         | mm(inch) | 680(26 <sup>27</sup> / <sub>32</sub> ) |

# Product Specifications

| ITEMS                            |                     | MODELS | LW1400ER<br>HBLG1453E  | HBLG1803R          | LW180CE<br>L1804R  |
|----------------------------------|---------------------|--------|--|--------------------|--------------------|
| POWER SUPPLY                     |                     |        | 1ø, 115V, 60Hz   | 1ø, 208/230V, 60Hz | 1ø, 208/230V, 60Hz |
| COOLING                          | CAPACITY (BTU/h)    |        | 14,500   | 18,000             | 17,500/18,000      |
|                                  | INPUT (W)           |        | 1,340  | 1,850              | 1,800/1,850        |
|                                  | RUNNING CURRENT (A) |        | 12.0   | 8.3                | 9.0/8.3            |
|                                  | E.E.R (BTU/W.h)     |        | 10.8   | 9.7                | 9.7/9.7            |
| OPERATING<br>CONDITION           | INDOOR (°C)         |        | 26.7(DB)* 19.4(WB)**   |                    |                    |
|                                  | OUTDOOR (°C)        |        | 35(DB)* 23.9(WB)**   |                    |                    |
| REFRIGERANT (R-22) CHARGE        |                     |        | 700g(24.3 oz)  | 690g(24.7 oz)      | 690g(24.3 oz)      |
| EVAPORATOR                       |                     |        | 2 ROW 11 STACKS, LOUVER-FIN TYPE   |                    |                    |
| CONDENSER                        |                     |        | 2 ROW 19 STACKS, STRAGHT TYPE  |                    |                    |
| FAN, INDOOR                      |                     |        | TURBO FAN  |                    |                    |
| FAN, OUTDOOR                     |                     |        | PROPELLER TYPE FAN WITH SLINGER RING   |                    |                    |
| FAN SPEEDS, FAN/COOLING/HEATING  |                     |        | 3/3  |                    |                    |
| FAN MOTOR                        |                     |        | 6 POLES  |                    |                    |
| OPERATION CONTROL                |                     |        | REMOTE CONTROLLER  |                    |                    |
| ROOM TEMP. CONTROL               |                     |        | THERMISTOR   |                    |                    |
| AIR DIRECTION CONTROL            |                     |        | VERTICAL LOUVER (RIGHT & LEFT)   |                    |                    |
|                                  |                     |        | HORIZONTAL LOUVER (UP & DOWN)  |                    |                    |
| CONSTRUCTION                     |                     |        | SLIDE IN-OUT CHASSIS   |                    |                    |
| PROTECTOR                        | COMPRESSOR          |        | OVERLOAD PROTECTOR   |                    |                    |
|                                  | FAN MOTOR           |        | INTERNAL THERMAL PROTECTOR   |                    |                    |
| POWER CORD                       |                     |        | 3 WIRE WITH GROUDING   |                    |                    |
|                                  |                     |        | ATTACHMENT PLUG (CORD-CONNECTED TYPE)  |                    |                    |
| DRAIN SYSTEM                     |                     |        | DRAIN PIPE OR SPLASHED BY FAN SLINGER  |                    |                    |
| NET WEIGHT                       | (lbs/kg)            |        | 126/57   |                    |                    |
| OUTSIDE DIMENSION<br>(W x H x D) | (inch)              |        | 25 <sup>31</sup> / <sub>32</sub> x 16 <sup>27</sup> / <sub>32</sub> x 26 <sup>27</sup> / <sub>32</sub> |                    |                    |
|                                  | (mm)                |        | 660 x 428 x 680  |                    |                    |

\* DB : dry bulb

\*\* WB : wet bulb

Note: Please refer to Label Quality on the product Since this sepcification may be changed for improving performance.

# Installation

## Select the Best Location

1. To avoid vibration and noise, make sure the unit is installed securely and firmly.
2. Install the unit where the sunlight does not shine directly on the unit.  
If the unit receives direct sunlight, build an awning to shade the cabinet.
3. There should be no obstacle, like a fence, within 20" which might restrict heat radiation from the condenser.
4. To prevent reducing performance, install the unit so that louvers of the cabinet are not blocked.
5. Install the unit a little obliquely outward not to leak the condensed water into the room (about 1/2" or 1/4 bubble with level).
6. Install the unit with its bottom portion 30~60" above the floor level.
7. Stuff the foam between the top of the unit and the wall to prevent air and insects from getting into the room.
8. The power cord must be connected to an independent circuit.  
The green wire must be grounded.
9. Connect the drain tube to the base pan hole in the rear side if you need to drain (consult a dealer).  
Plastic hose or equivalent may be connected to the drain tube.

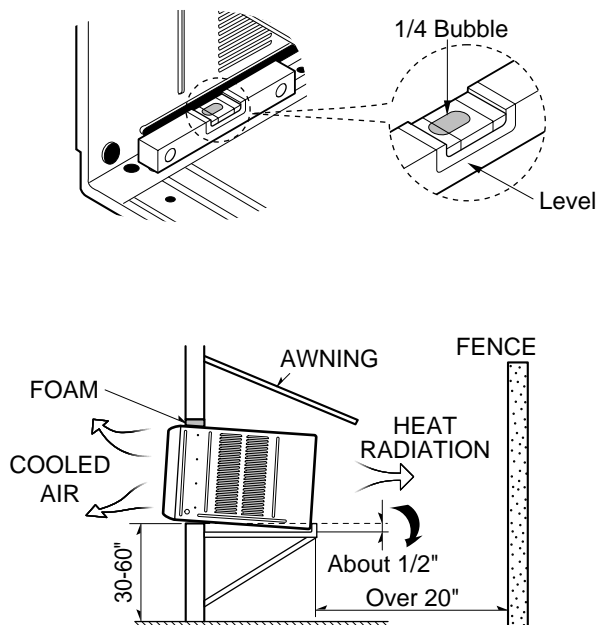

Figure 1

## Installation Check

The setting conditions must be checked prior to initial starting.

The following items are especially important check points when the installation is finished.

1. Grounding wire (Green or Green and Yellow) is provided in the power cord. The green wire must be grounded.
2. Connect to a single-outlet 15A circuit.  
(or 20A circuit for Electric Heater Model)
3. To avoid vibration or noise, make sure the air conditioner is installed securely.
4. Avoid placing furniture or draperies in front of the air inlet and outlet.

## How to Secure the Drain Pipe

In humid weather, excess water may cause the BASE PAN to overflow. To drain the water, remove the DRAIN CAP and secure the DRAIN PIPE to the rear hole of the BASE PAN. Press the drain pipe into the hole by pushing down and away from the fins to avoid injury.

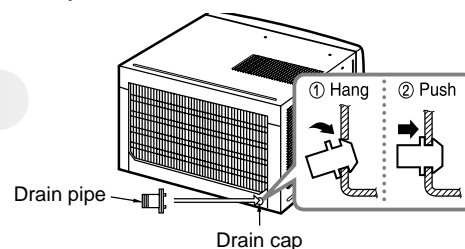

## Optional

1. Install the drain pan over the corner of the cabinet where you removed the plug with 4 (or 2) screws.
2. Connect the drain hose to the outlet located at the bottom of the drain pan. You can purchase the drain hose or tubing locally to satisfy your particular needs. (Drain hose is not supplied).
3. Select the most appropriate connection from among the following figures (by considering the hole of the unit) to fit drain pan to your own unit.

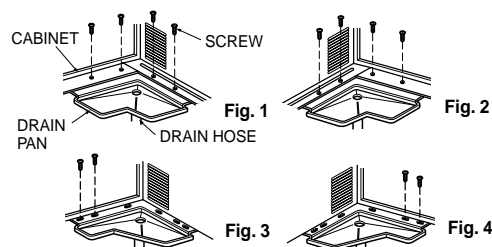

# How to Install

## When Using Installation Kits

### 1. Window Requirements

This unit is designed for installation in standard double hung windows with actual opening widths from 29" to 41".

The top and bottom window sash must open sufficiently to allow a clear vertical opening of 16" from the bottom of the upper sash to the window stool.

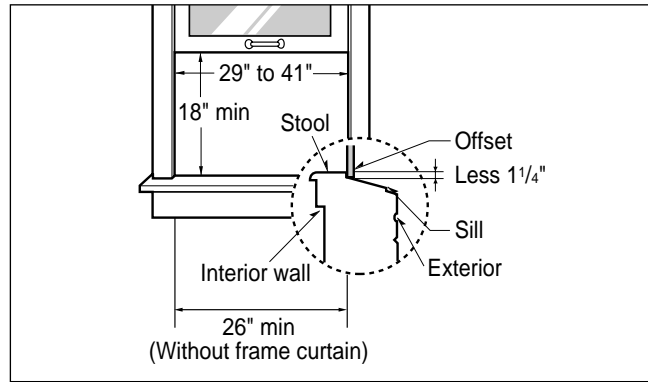

### 2. Installation Kits Contents

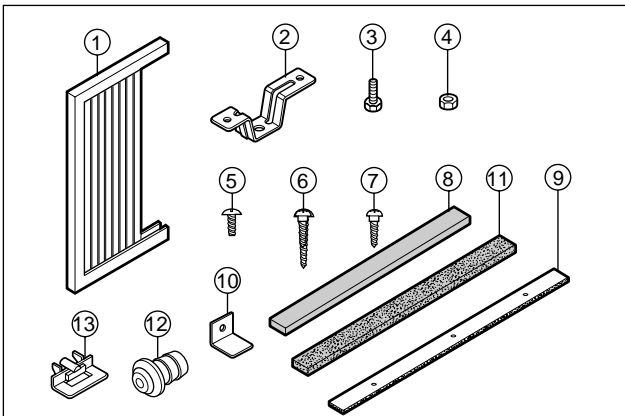

■ Top retainer bar is in the product package.

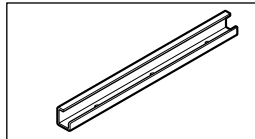

| NO. | NAME OF PARTS  | Q'TY |
|-----|--|------|
| 1   | FRAME CURTAIN  | 2    |
| 2   | SILL SUPPORT   | 2    |
| 3   | BOLT   | 2    |
| 4   | NUT  | 2    |
| 5   | SCREW(TYPE A) (10mm( <sup>2</sup> / <sub>5</sub> ")) | 16   |
| 6   | SCREW(TYPE B) D5.1mm(0.2")/16mm(0.63")               | 3    |
| 7   | SCREW(TYPE C) D4.1mm(0.17")/16mm(0.63")              | 5    |
| 8   | FOAM-STRIP   | 1    |
| 9   | FOAM-PE (600mm x 25mm x 2mm)                         | 1    |
| 10  | WINDOW LOCKING BRACKET                               | 1    |
| 11  | FOAM-PE (920mm x 30mm x 2mm)                         | 1    |
| 12  | DRAIN PIPE   | 1    |
| 13  | FRAME GUIDE  | 2    |



## Cabinet Installation

1. Open the window. Mark a line on the center of the window stool between the side window stop moldings. Loosely attach the sill bracket to the support bracket using the carriage bolt and the lock nut.

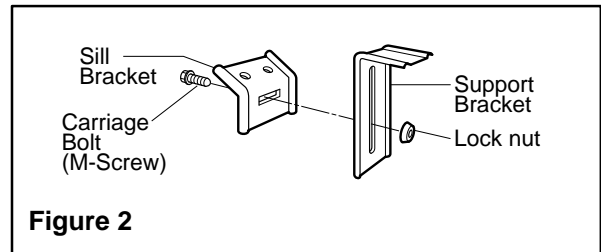

2. Attach the sill bracket to the window sill using the screws (Type B). Carefully place the cabinet on the window stool and align the center mark on the bottom front with the center line marked window stool.

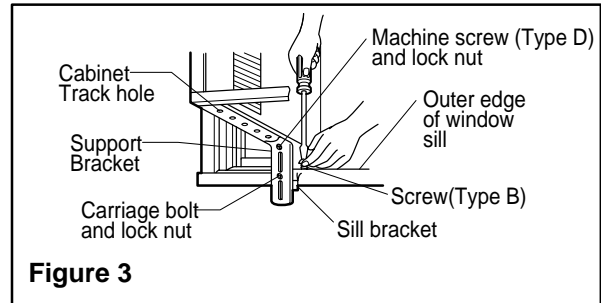

3. Using the M-screw and the lock nut, attach the support bracket to the cabinet track hole. Use the first track hole after the sill bracket on the outer edge of the window sill. Tighten the carriage bolt and the lock nut. Be sure the cabinet slants outward.



**CAUTION: Do not drill a hole in the bottom pan. The unit is designed to operate with approximately 1/2" of water in bottom pan.**

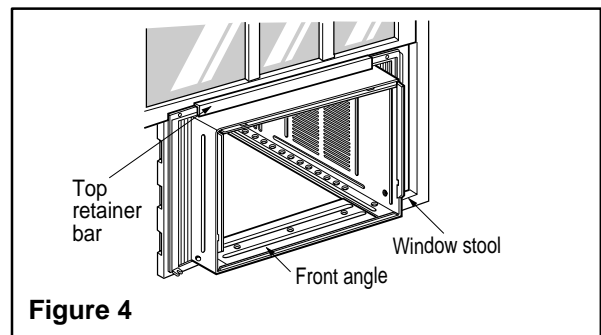

4. Pull the bottom window sash down behind the Top retainer bar until they meet.

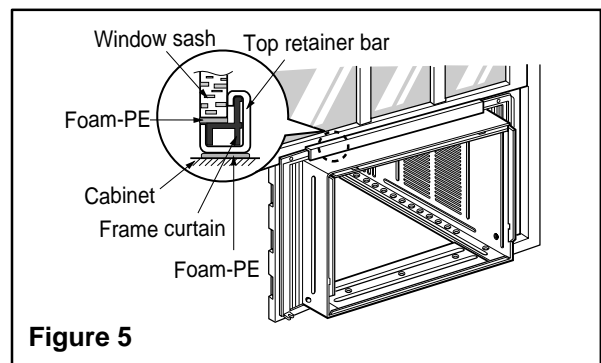

### NOTICE

1. Do not pull the window sash down so tightly that the movement of Frame curtain is restricted. Attach the cabinet to the window stool by driving the screws (Type B) through the cabinet into window stool.
2. The cabinet should be installed with a very slight tilt downward toward the outside.

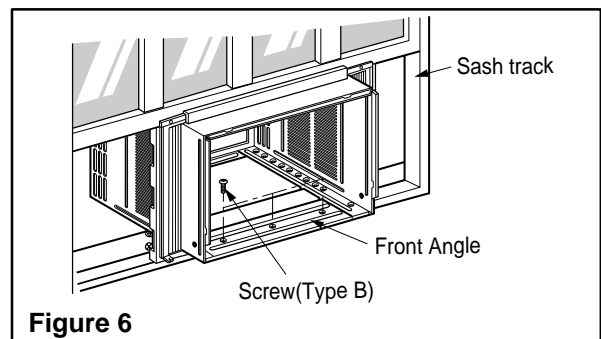

5. Pull each Frame curtain fully to each window sash track, and pull the bottom window sash down behind the Top retainer bar until it meets.

6. Attach each Frame curtain the window sash by using screws (Type C). (See Fig. 7)

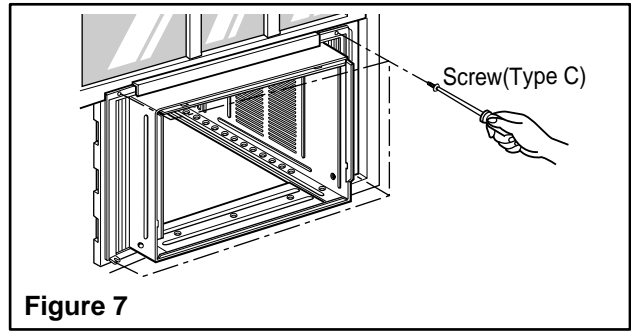

Figure 7

7. Slide the unit into the cabinet. (See Fig. 8)

**CAUTION: For security purpose, reinstall screws (Type A) at cabinet's sides.**

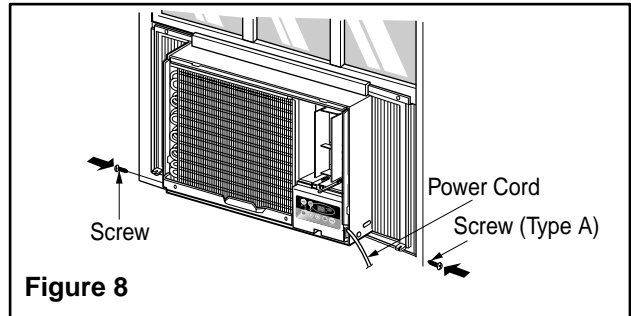

Figure 8

8. Cut the Foam-strip to the proper length and insert between the upper window sash and the lower window sash. (See Fig. 9)

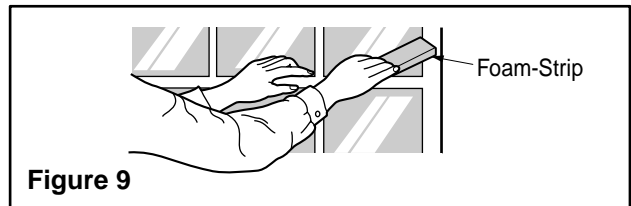

Figure 9

9. Attach the Window locking bracket with a screw (Type C). (See Fig. 10)

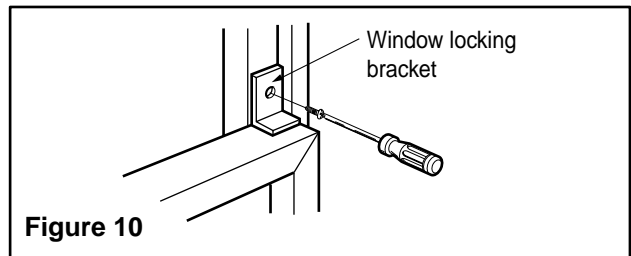

Figure 10

10. Attach the front grille to the cabinet by inserting the tabs on the grille into the tabs on the front of the cabinet. Push the grille in until it snaps into place. (See Fig.11)

11. Lift the inlet grille and secure it with a screw (Type A) through the front grille. (See Fig. 11)

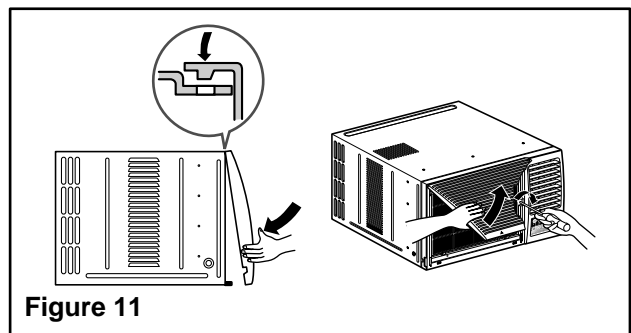

Figure 11

12. **Window installation of room air conditioner is now completed.**

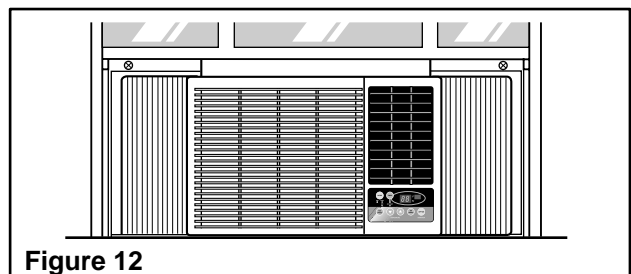
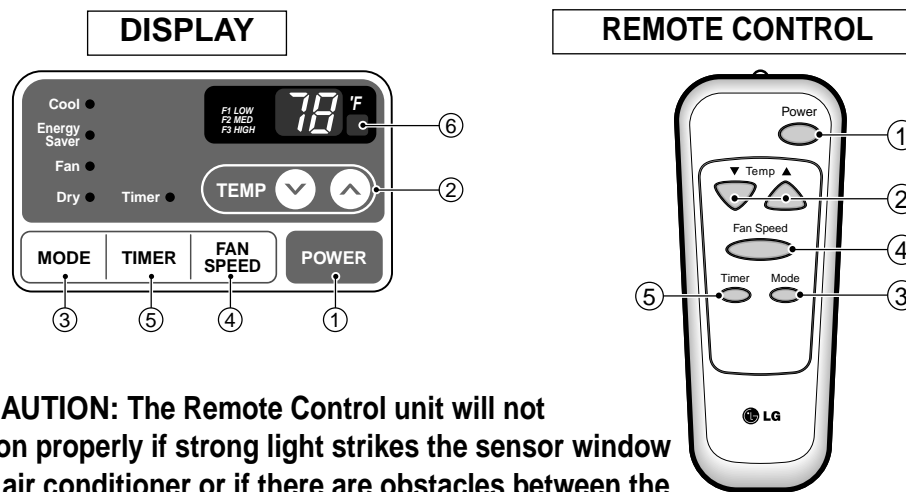

Figure 12

# Operation

## Function of Controls

- Designed for COOLING ONLY.
- Powerful and quiet cooling.
- Slide-in and slide-out chassis for the simple installation and service.
- Low air-intake, top cooled-air discharge.
- Built-in adjustable Thermistor
- Washable one-touch filter
- Compact size
- Equipped with reliable and efficient rotary compressor.



**PRECAUTION:** The Remote Control unit will not function properly if strong light strikes the sensor window of the air conditioner or if there are obstacles between the Remote Control unit and the air conditioner.

### 1 POWER BUTTON

To turn the air conditioner ON, push the button. To turn the air conditioner OFF, push the button again. This button takes priority over any other buttons.

### 2 ROOM TEMPERATURE SETTING BUTTON

This button can automatically control the temperature of the room. The temperature can be set within a range of 60°F to 86°F by 1°F. (16°C to 30°C by 1°C)  
Select the lower number for lower temperature of the room.

### 3 OPERATION MODE SELECTION BUTTON

Every time you push this button, it will shift among COOL, ENERGY SAVER, FAN and DRY.

- Energy Saver: If Energy Save mode is selected, the fan stops when the compressor stops cooling. a  
Approximately every 3 minutes the fan will turn on and check the room air to determine if cooling is needed.

### 4 FAN SPEED SELECTOR

Every time you push this button, it is set as follows.  
(Hi [F3] → Low [F1] → Med [F2] → Hi [F3] → Low [F1] →...)

### 5 ON/OFF TIMER BUTTON

You can set the time when the unit will turn on or turn off automatically by pressing the timer button. If the unit is operating, this button controls the time it will be turned off. If the unit is off state, this button controls the time it will start. Every time you push this button, the remaining time will be set as follows.

- Stopping operation  
(1Hour → 2Hours → 3Hours → 4Hours → 5Hours → 6Hours → 7Hours → 8Hours → 9Hours → 10Hours → 11Hours → 12Hours → 0Hour → 1Hour → 2Hours → ... )

- Starting operation  
(1Hour → 2Hours → 3Hours → 4Hours → 5Hours → 6Hours → 7Hours → 8Hours → 9Hours → 10Hours → 11Hours → 12Hours → off → 1Hour → 2Hours → ... )

### 6 REMOCON SIGNAL RECEIVER

# Disassembly

— Before the following disassembly, **CONTROL BOX** set to OFF and disconnect the power cord.

## Mechanical Parts

### 1. Front Grille

1. Open the Inlet grille downward and remove the air filter.
2. Remove the screw that fastens the front grille.(See Figure 13)
3. Pull the front grille from the right side.
4. Remove the front grille.(There are 4 hooks.)
5. Re-install the components by referring to the removal procedure, above.

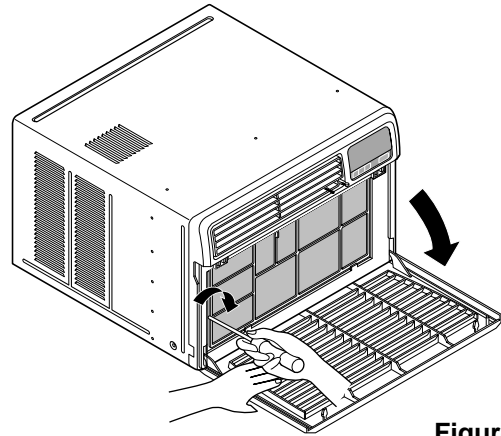

Figure 13

### 2. Cabinet

1. After disassembling the FRONT GRILLE, remove the 2 screws that fasten the cabinet at both sides.
2. Remove the 2 screws that fasten the cabinet at back.
3. Pull the base pan forward. (See Figure 14)
4. Remove the cabinet.
5. Re-install the components by referring to the removal procedure, above.

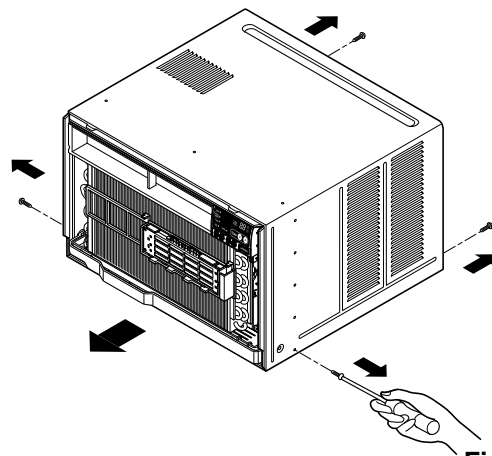

Figure 14

### 3. Control Box

1. Remove the front grille. (Refer to section 1)
2. Remove the cabinet. (Refer to section 2)
3. Remove the 2 screws which fasten the power cord.
4. Disconnect the grounding screw from the evaporator channel.
5. Remove the 1 screw that fastens the control box cover.
6. Remove the housing that connects PCB and motor wire in the control box.
7. Disconnect the housing that connects Plasma Air Purifier.(Optional)
8. Remove the screw at left cover of filter case and open the cover to remove inner screw. (Optional)
9. Remove the nut that fastens the terminal cover.
10. Remove the terminal cover.
11. Remove all the leads from the overload protector.
12. Discharge the capacitor by placing a 20,000 ohm resistor across the capacitor terminals.
13. Raise the control box upward completely. (See Figure 15)
14. Re-install the components by referring to the removal procedure, above. (Refer to the wiring diagram found on page 22 in this manual and on the control box.)

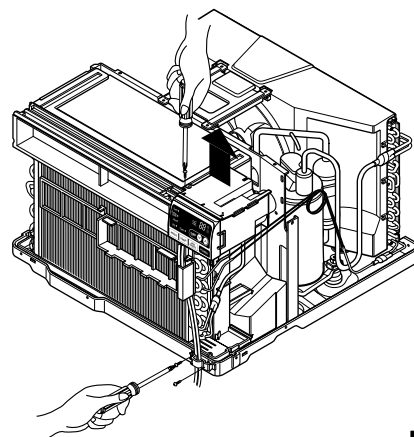

Figure 15

## Air Handling Parts

### 4. Air Guide and Turbo Fan

1. Remove the front grille. (Refer to section 1)
2. Remove the cabinet. (Refer to section 2)
3. Remove the control box. (Refer to section 3)
4. Remove the 4 screws that fasten the brace.
5. Remove the brace.
6. Remove the 2 screws that fasten the air guide upper.
7. Remove the air guide upper. (See Figure 16)
8. Remove the 2 screws that fasten the evaporator.
9. Move the evaporator forward and pulling it upward slightly. (See Figure 17)
10. Pull out the hook of orifice by pushing the tabs and remove it. (See Figure 18)
11. Remove the clamp with a hand plier that secures the turbo fan.
12. Remove the turbo fan.
13. Remove the 2 screws that fasten the air guide from the base pan.
14. Move the air guide backward, and pull out from the base pan. (Move the air guide lower carefully.)
15. Re-install the components by referring to the removal procedure, above.

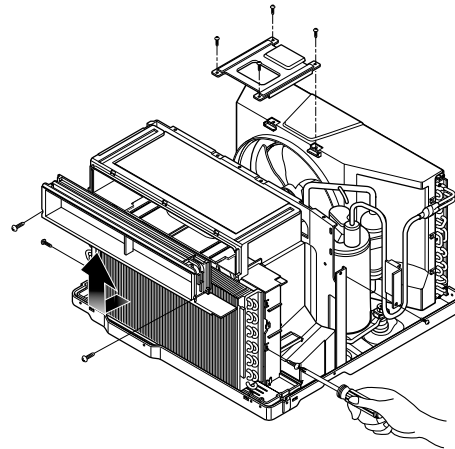

Figure 16

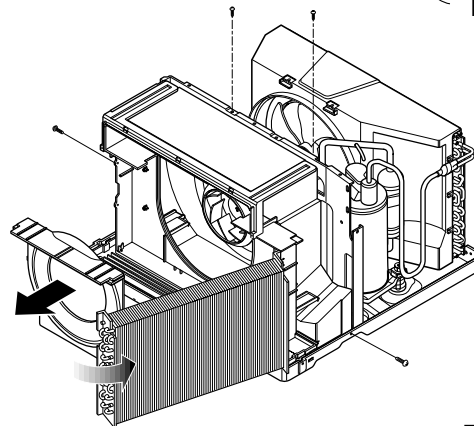

Figure 17

### 5. FAN

1. Remove the cabinet. (Refer to section 2)
2. Remove the brace (Refer to section 4)
3. Remove the 5 screws that fasten the condenser.
4. Move the condenser to the left carefully.
5. Remove the clamp that secures the fan.
6. Remove the fan. (See Figure 19)
7. Re-install by referring to the removal procedure.

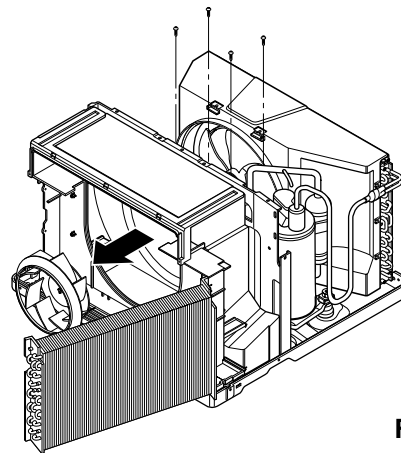

Figure 18

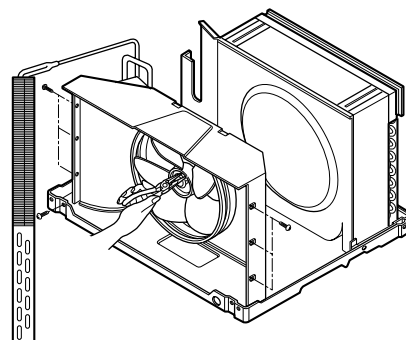

Figure 19

## 6. Shroud

1. Remove the fan. (Refer to section 5)
2. Remove the shroud. (See Figure 20)
3. Re-install the components by referring to the removal procedure, above.

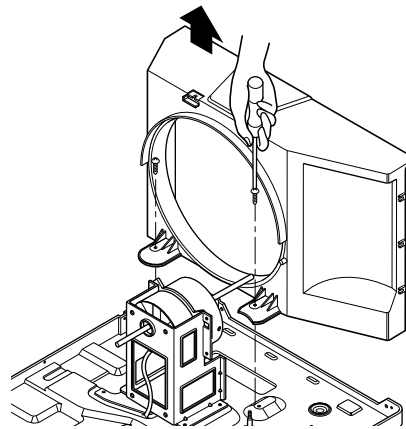

Figure 20

## Electrical Parts

### 7. Overload Protector

1. Remove the cabinet. (Refer to section 2)
2. Remove the nut that fastens the terminal cover.
3. Remove the terminal cover. (See Figure 21)
4. Remove all the leads from the overload protector.
5. Remove the overload protector.
6. Re-install the components by referring to the removal procedure, above.

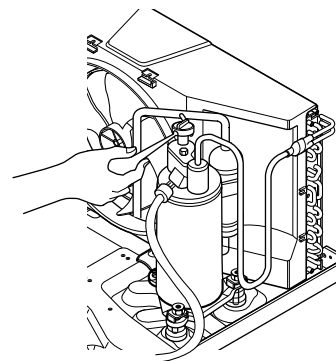

Figure 21

### 8. Compressor

1. Remove the cabinet. (Refer to section 2)
2. Discharge the refrigerant system using a Freon™ Recovery System.  
If there is no valve to attach the recovery system, install one (such as a WATCO A-1) before venting the Freon™. Leave the valve in place after servicing the system.
3. Remove the overload protector. (Refer to section 7)
4. After purging the unit completely, unbraid the suction and discharge tubes at the compressor connections.
5. Remove the 3 nuts and the 3 washers which fasten the compressor.
6. Remove the compressor. (See Figure 22)
7. Re-install the components by referring to the removal procedure, above.

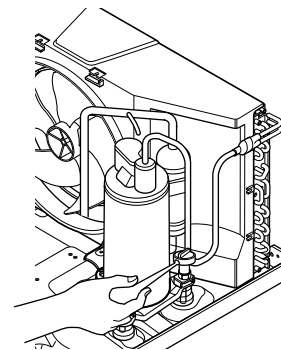

Figure 22

## 9. Capacitor

1. Remove the control box. (Refer to section 3)
2. Open the top cover from the control box. (See Figure 23)
3. Pull out the capacitor from the control box.
4. Disconnect all the leads of capacitor terminals.
5. Re-install the components by referring to the removal procedure, above.

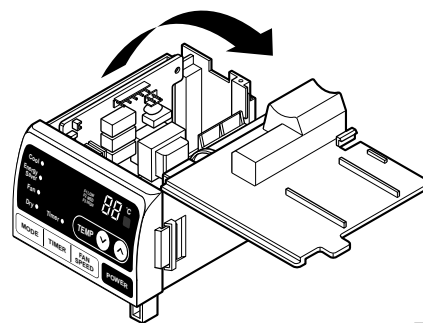

Figure 23

## 10. Power Cord

1. Remove the control box. (Refer to section 3)
2. Open the top cover from the control box. (Refer to section 9)
3. Disconnect the front panel from the control box. (See Figure 24)
4. Disconnect two leads from the capacitor and relay.
5. Pull out the power cord.
6. Re-install the component by referring to the above removal procedure, above. (Use only one ground-marked hole for ground connection.)
7. If the supply cord of this appliance is damaged, it must be replaced by the special cord. (The special cord means the cord which has the same specification marked on the supply cord attached at the unit.)

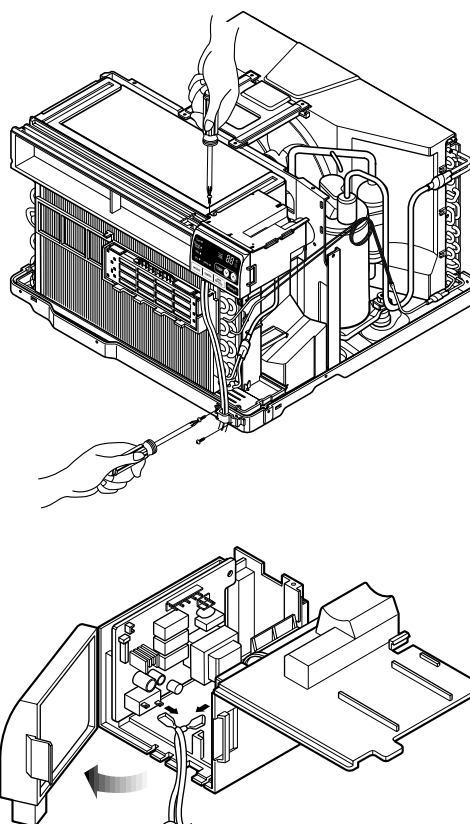

Figure 24

## 11. Motor

1. Remove the cabinet. (Refer to section 2)
2. Remove the turbo fan. (Refer to section 4)
3. Remove the fan. (Refer to section 5)
4. Remove the 4 screws that fasten the motor from the air guide. (See Figure 25)
5. Remove the motor.
6. Re-install the components by referring to the removal procedure, above.(See Figure 25)

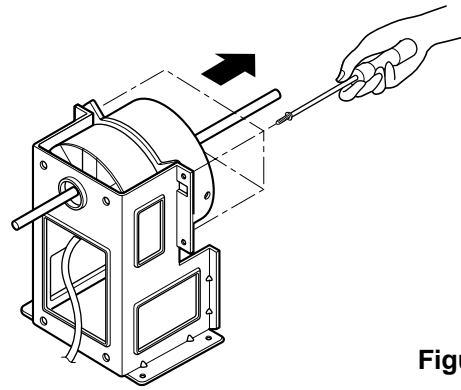

Figure 25

## Refrigerating Cycle

### 12. Condenser

**CAUTION:** Discharge the refrigerant system using a Freon™ Recovery System. If there is no valve to attach the recovery system, install one (such as a WATCO A-1) before venting the Freon™. Leave the valve in place after servicing the system.

1. Remove the cabinet. (Refer to section 2)
2. Remove the 4 screws that fasten the brace.(Refer to section 4)
3. Remove the 5 screws that fasten the condenser and shroud.
4. After discharging the refrigerant completely, unbraid the interconnecting tube at the condenser connections.
5. Remove the condenser.
6. Re-install the components by referring to notes. (See Figure 26)

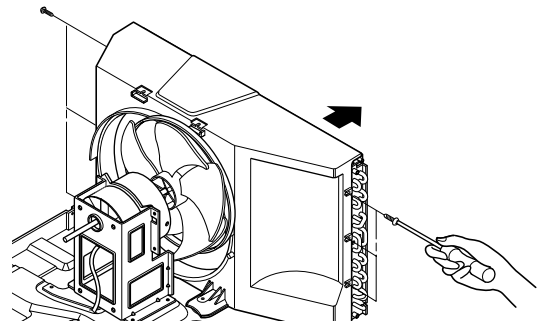

Figure 26

### 13. Evaporator

1. Remove the control box.(Refer to section 3)
2. Remove the air guide upper. (Refer to section 4)
3. Remove the 2 screws that fasten the evaporator.
4. Move the evaporator sideways carefully. (Refer to section 4)
5. After discharging the refrigerant completely, unbraid the interconnecting tube at the evaporator connections.
6. Remove the evaporator.
7. Re-install the components by referring to notes. (See Figure 27)

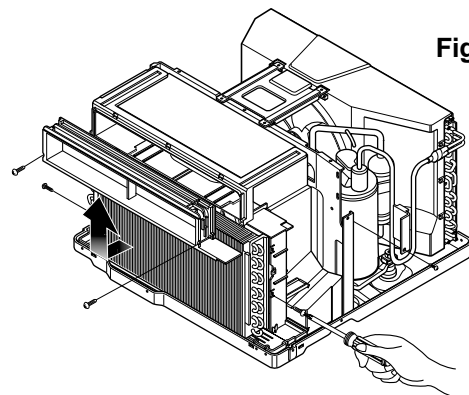

Figure 27



## 14. Capillary Tube

1. Remove the cabinet. (Refer to section s2)
2. After discharging the refrigerant completely, unbrazed the interconnecting tube at the capillary tube. (See caution above)

### NOTICE

— Replacement of the refrigeration cycle.

1. When replacing the refrigeration cycle, be sure to discharge the refrigerant system using a Freon™ recovery System.  
If there is no valve to attach the recovery system, install one (such as a WATCO A-1) before venting the Freon™. Leave the valve in place after servicing the system.
2. After discharging the unit completely, remove the desired component, and unbrazed the pinch-off tubes.
3. Brazed service valves into the pinch-off tube ports, leaving the valves open.
4. Brazed the pinch-off tubes with Service valves.
5. Evacuate as follows.
  - 1) Connect the vacuum pump, as illustrated figure 28A.
  - 2) Start the vacuum pump, slowly open manifold valves A and B with two full turns counterclockwise and leave the valves open.  
The vacuum pump is now pulling through valves A and B up to valve C by means of the manifold and entire system.

**CAUTION:** If high vacuum equipment is used, just crack valves A and B for a few minutes, then open slowly with the two full turns counterclockwise. This will keep oil from foaming and being drawn into the vacuum pump.

- 3) Operate the vacuum pump vacuum for 20 to 30 minutes, until 600 microns of vacuum is obtained. Close valves A and B, and observe vacuum gauge for a few minutes. A rise in pressure would indicate a possible leak or moisture remaining in the system. With valves A and B closed, stop the vacuum pump.
- 4) Remove the hose from the vacuum pump and place it on the charging cylinder. See figure 29B.  
Open valve C.  
Discharge the line at the manifold connection.
- 5) The system is now ready for final charging.

3. Remove the capillary tube.
4. Re-install the components by referring to notes.

6. Recharge as follows :
  - 1) Refrigeration cycle systems are charged from the High-side. If the total charge cannot be put in the High-side, the balance will be put in the suction line through the access valve which you installed as the system was opened.
  - 2) Connect the charging cylinder as shown in figure 28B.  
With valve C open, discharge the hose at the manifold connection.
  - 3) Open valve A and allow the proper charge to enter the system. Valve B is still closed.
  - 4) If more charge is required, the high-side will not take it. Close valve A.
  - 5) With the unit running, open valve B and add the balance of the charge.
    - a. Do not add the liquid refrigerant to the Low-side.
    - b. Watch the Low-side gauge; allow pressure to rise to 30 lbs.
    - c. Turn off valve B and allow pressure to drop.
    - d. Repeat steps b. and c. until the balance of the charge is in the system.
  - 6) When satisfied the unit is operating correctly, use the pinch-off tool with the unit still running and clamp on to the pinch-off tube. Using a tube cutter, cut the pinch-off tube about 2 inches from the pinch-off tool. Use sil-fos brazing and braze pinch-off tube closed. Turn off the unit, allow it to set for a while, and then test the leakage of the pinch-off connection.

**Equipment needed:** Vacuum pump, Charging cylinder, Manifold gauge, Brazing equipment. Pin-off tool capable of making a vapor-proof seal, Leak detector, Tubing cutter, Hand Tools to remove components, Service valve.

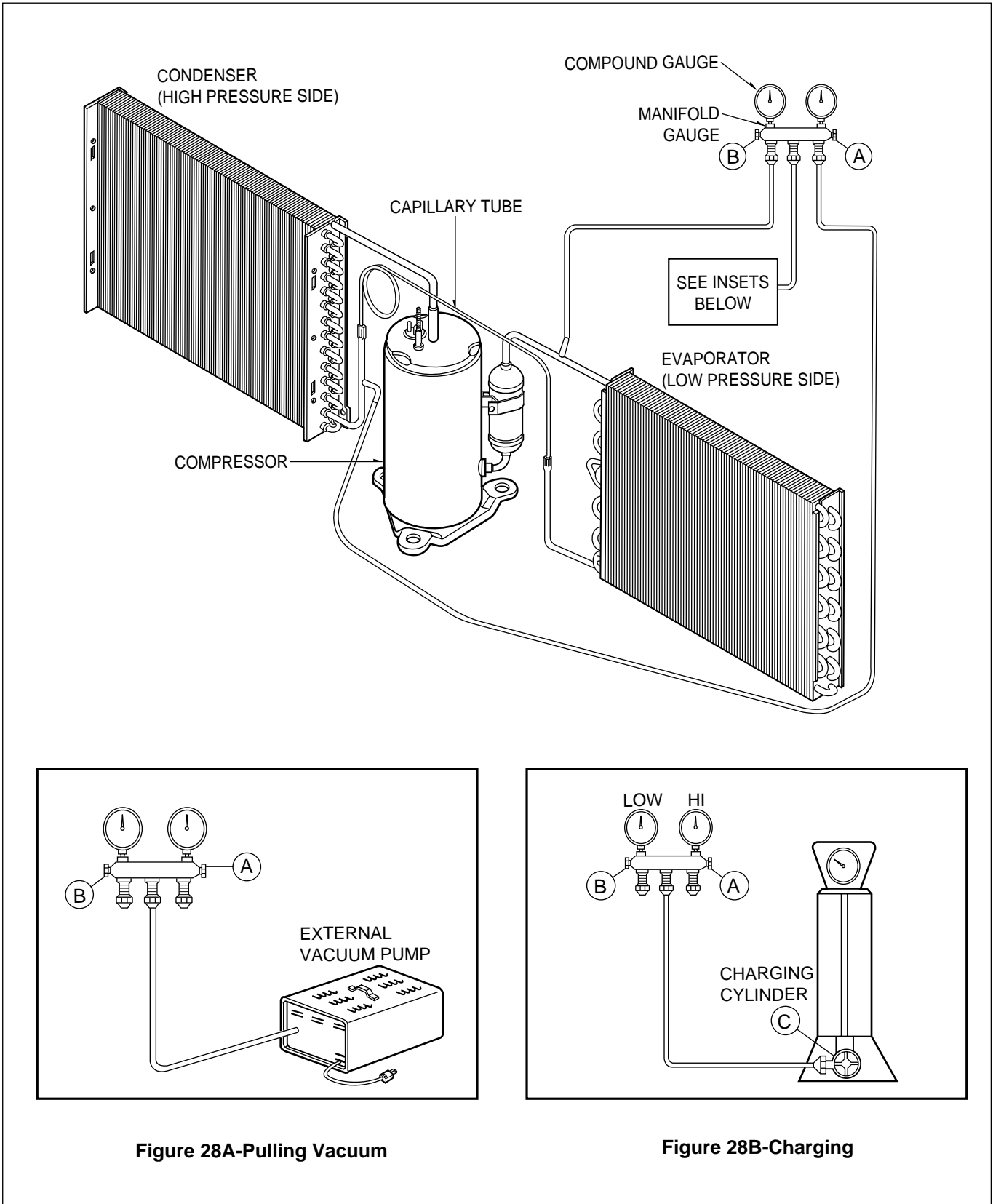

# Schematic Diagram

## Electronic Control Device

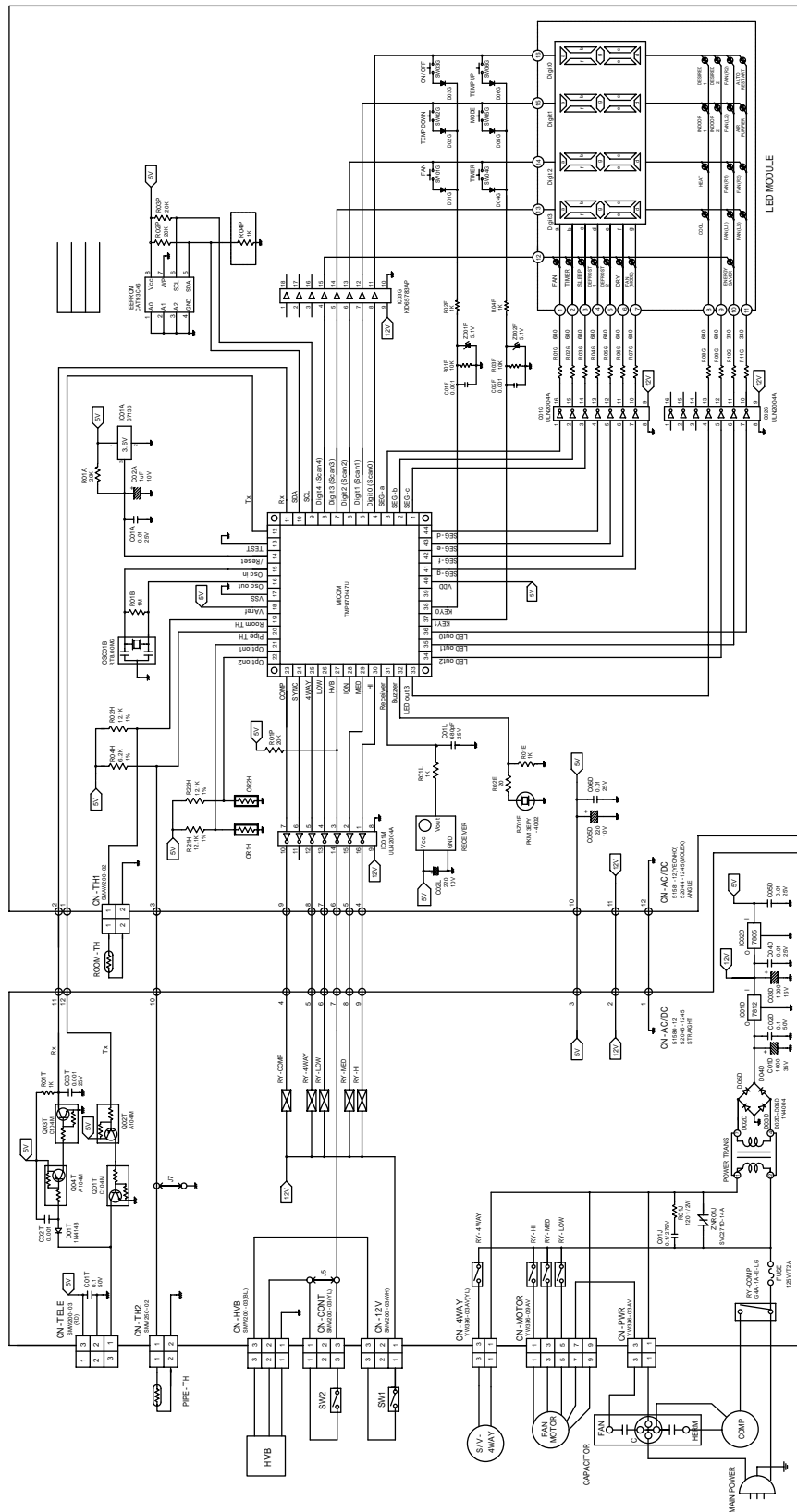

# Wiring Diagram

**• 18K MODELS**

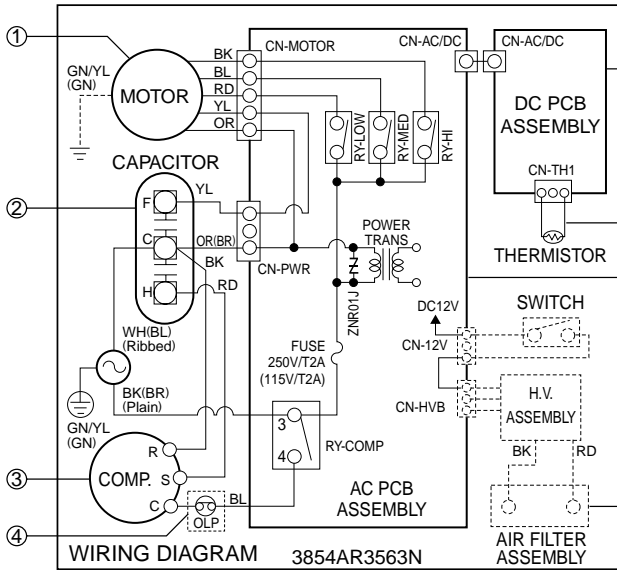

**• 15K MODELS**

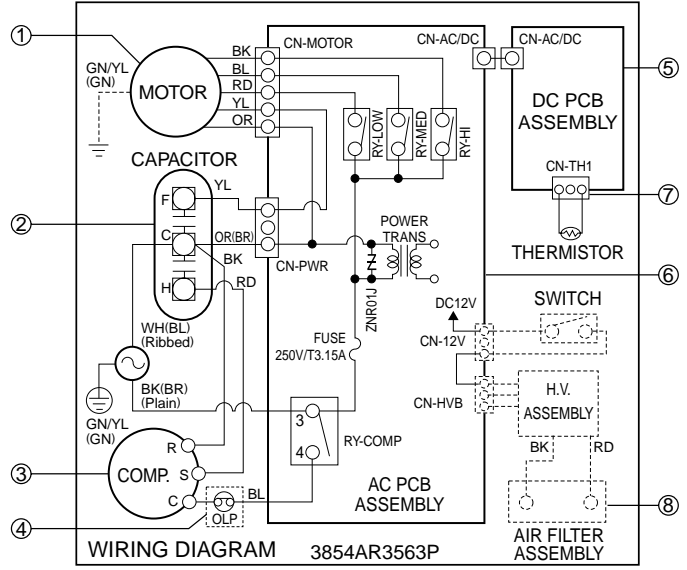

S: Service Parts  
N: Non Service Parts

| LOCATION NO. | DESCRIPTION        | Q'TY PER SET | REMARKS |
|--------------|--------------------|--------------|---------|
| 1            | MOTOR ASSY         | 1            | S       |
| 2            | CAPACITOR          | 1            | S       |
| 3            | COMPRESSOR         | 1            | S       |
| 4            | OVERLOAD PROTECTOR | 1            | S       |
| 5            | DC PCB ASSEMBLY    | 1            | S       |
| 6            | AC PCB ASSEMBLY    | 1            | S       |
| 7            | THERMISTOR         | 1            | S       |
| 8            | PLASMA FILTER ASSY | 1            | S       |

# Components Location

## 1. MAIN P.C.B ASSEMBLY

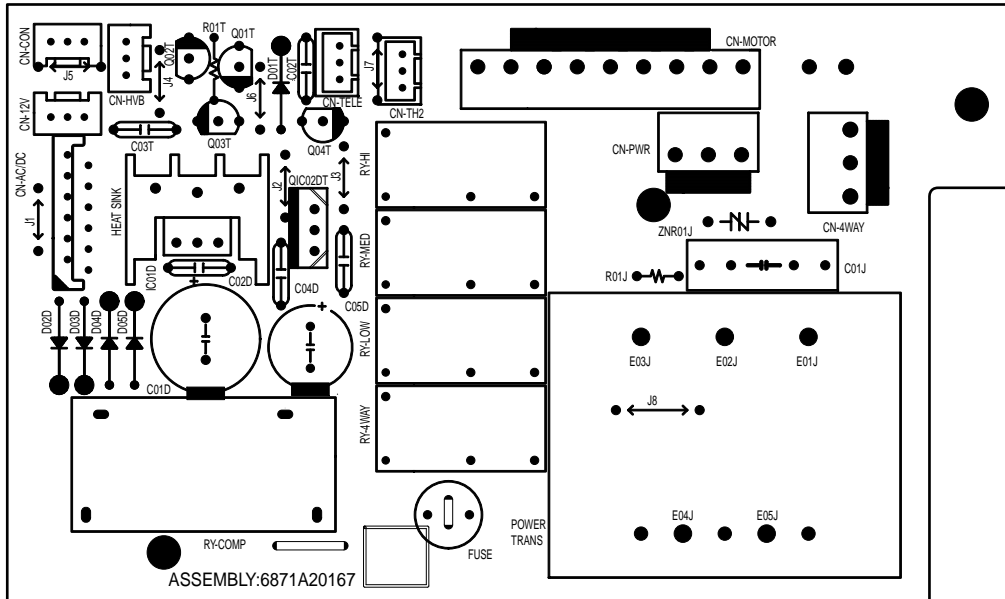

## 2. DISPLAY P.C.B. ASSEMBLY

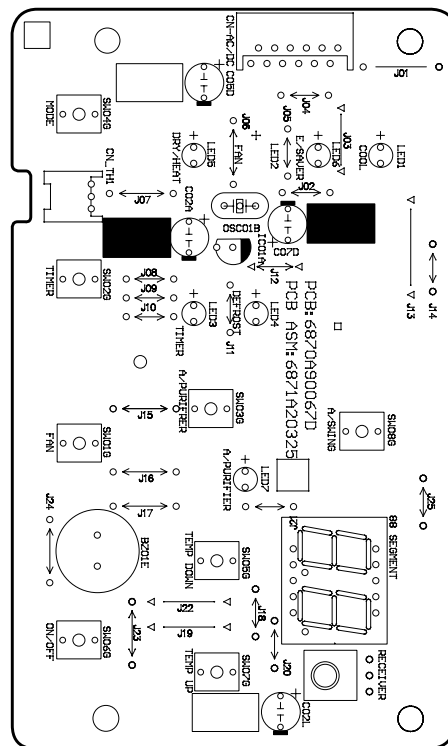
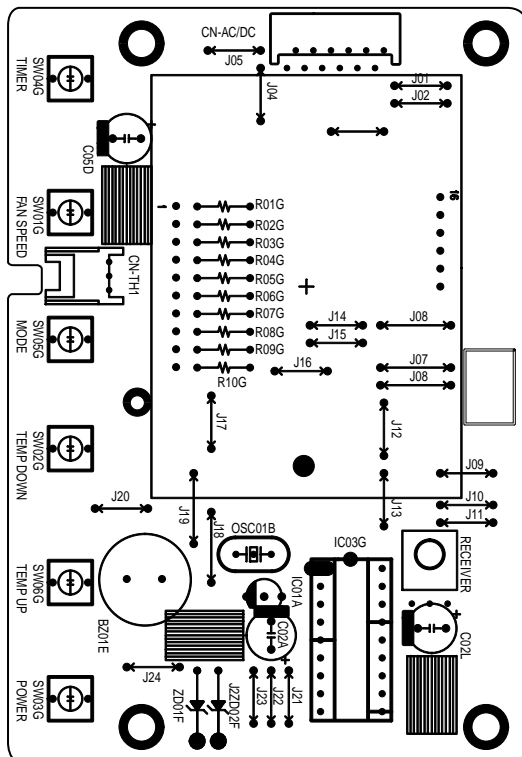

# Troubleshooting Guide

## Piping System

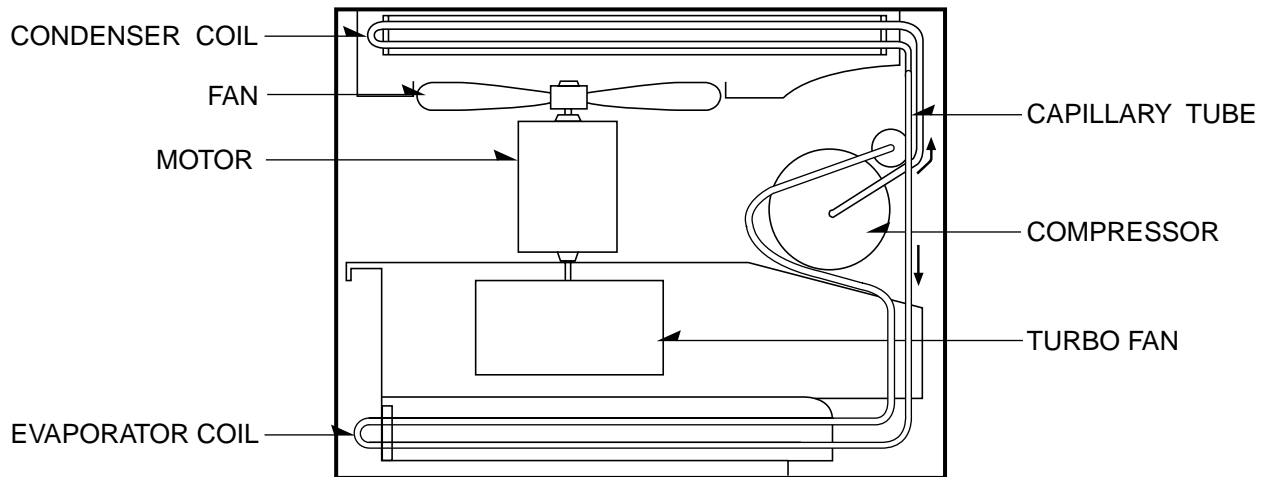
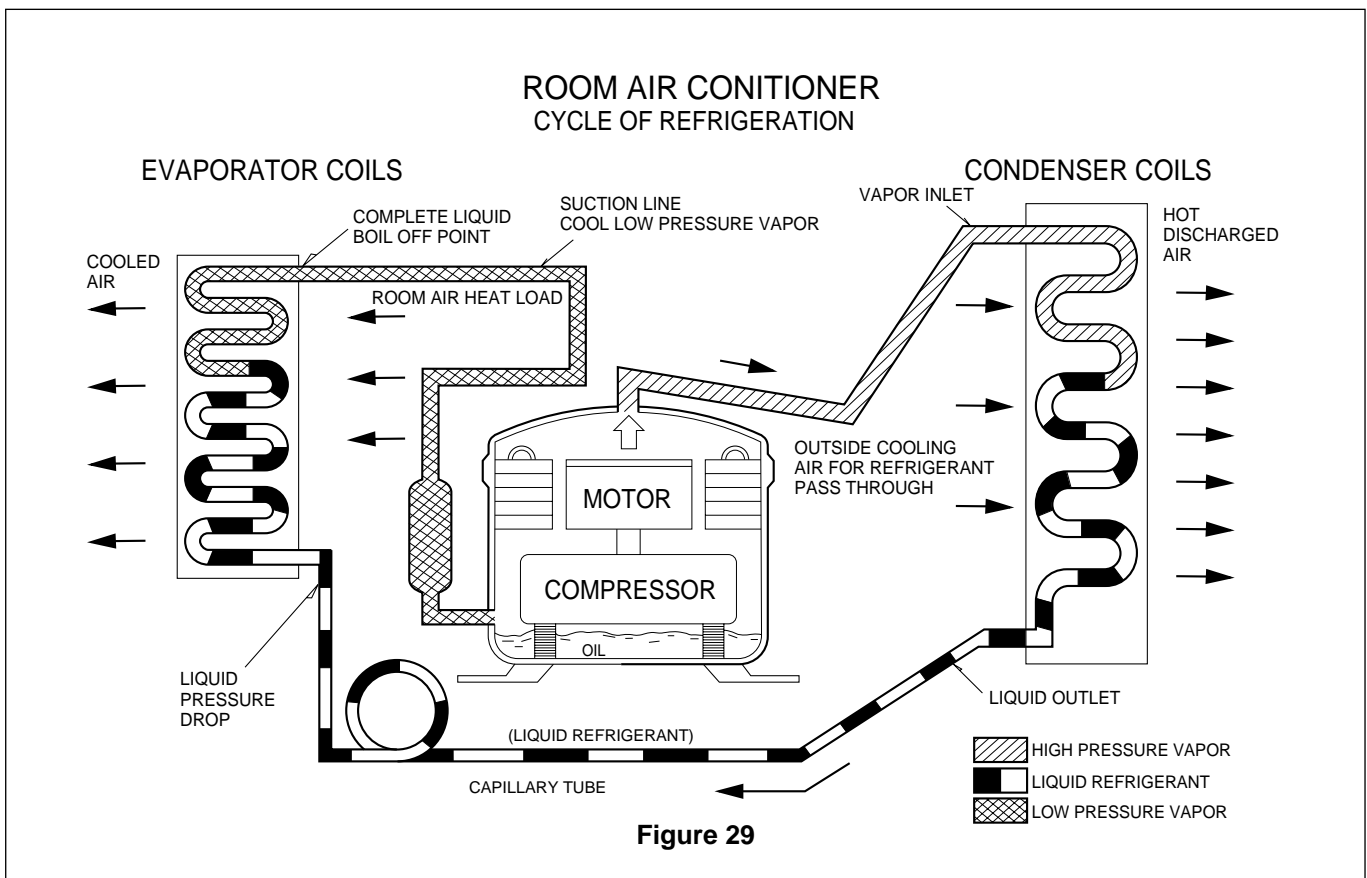

Figure 29 is a brief description of the important components and their function in what is called the refrigeration system. This will help you to understand the refrigeration cycle and the flow of the refrigerant in the cooling cycle.



## Troubleshooting Guide

In general, possible trouble is classified in two kinds.

The one is called Starting Failure which is caused from an electrical defect, and the other is ineffective Air Conditioning caused by a defect in the refrigeration circuit and improper application.

### Unit runs but poor cooling.

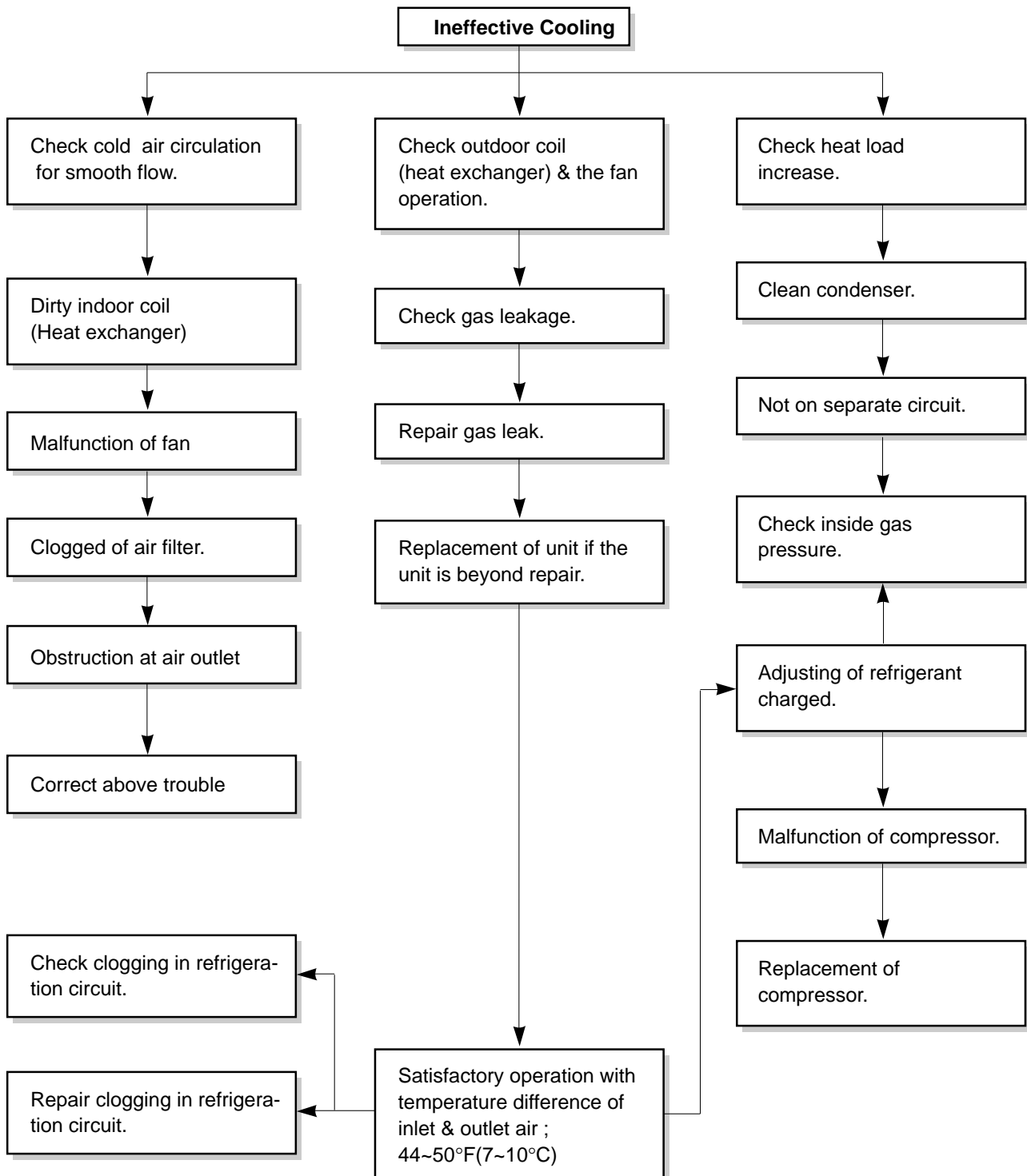

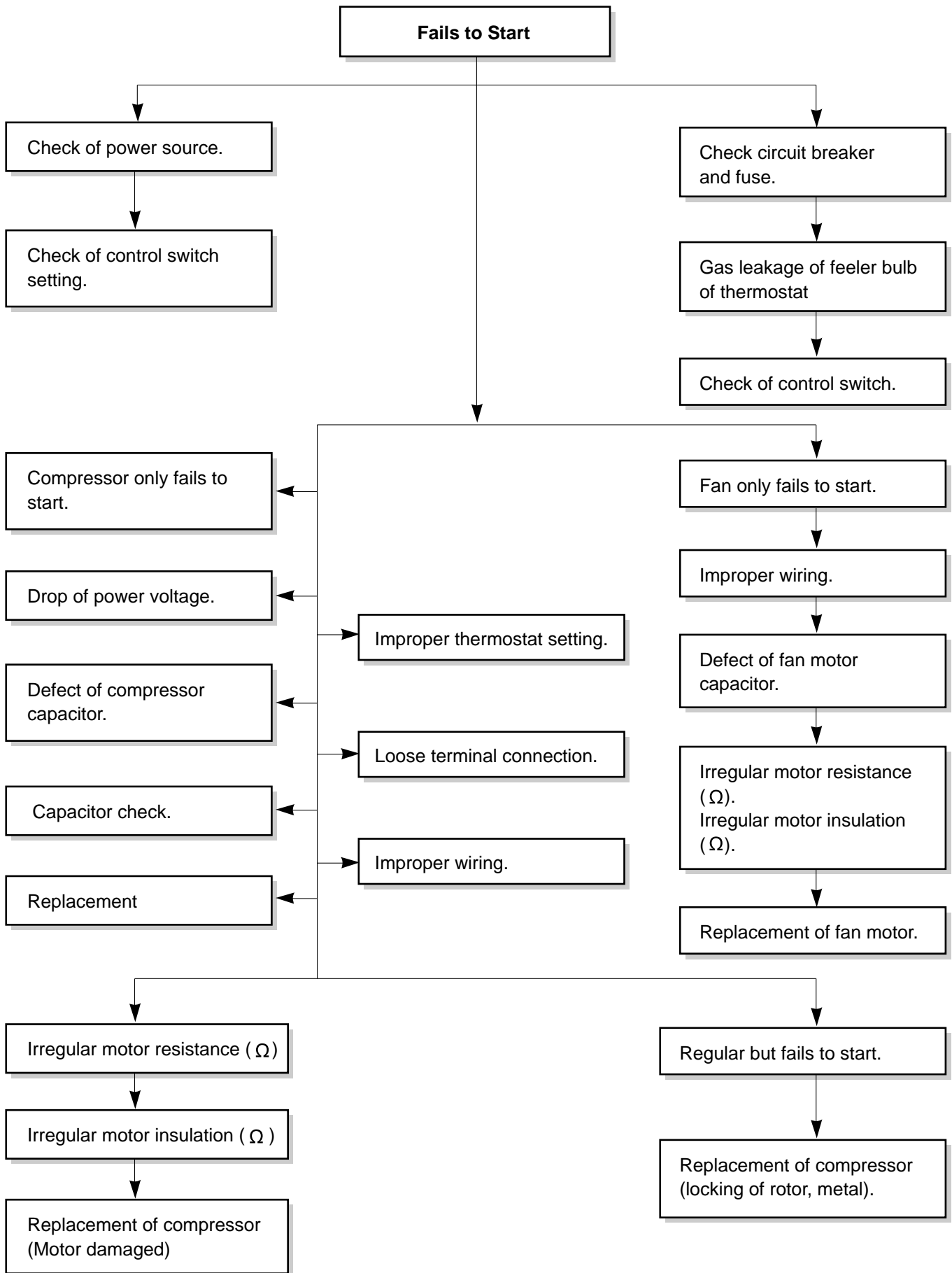



# Electrical Parts Troubleshooting Guide

**Possible Trouble 1**

The unit does not operate.

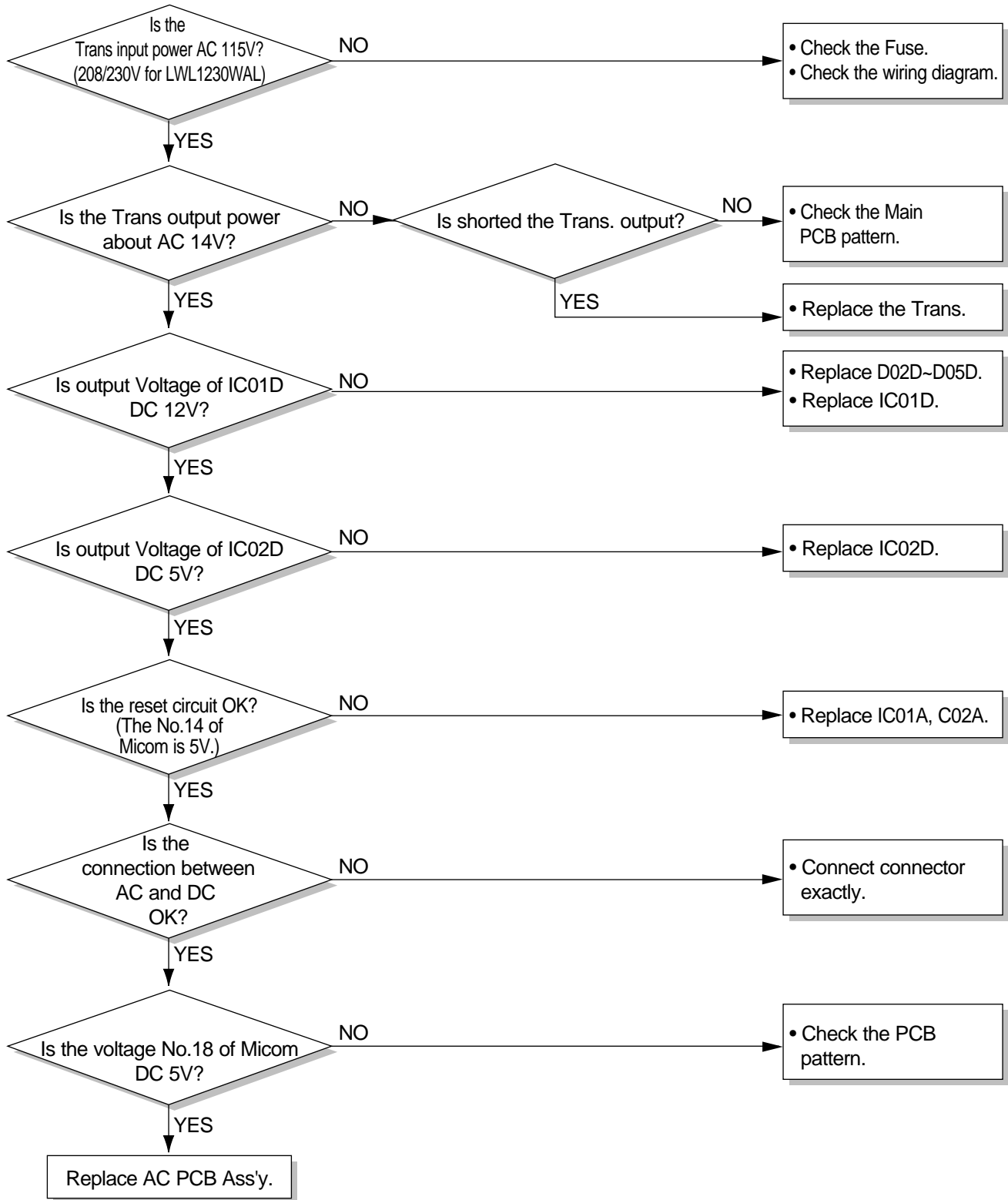

**Possible Trouble 2**

The compressor does not operate.

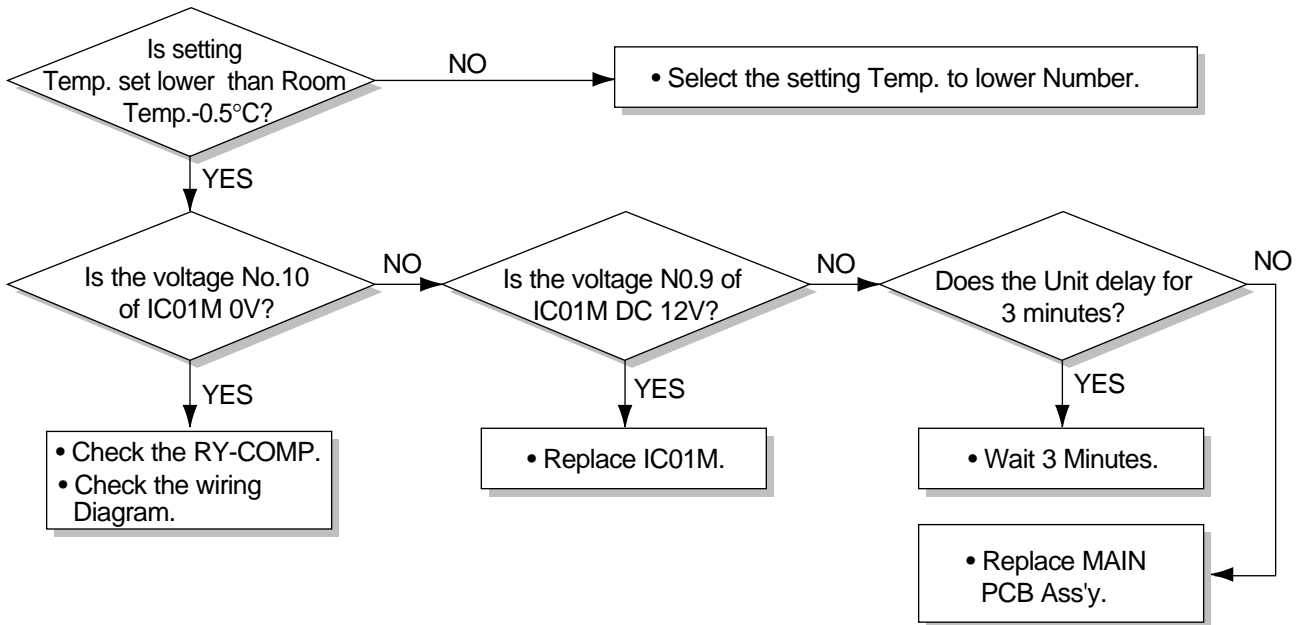

**Possible Trouble 3**

The compressor always operate.



**Possible Trouble 4**

FAN does not operate.

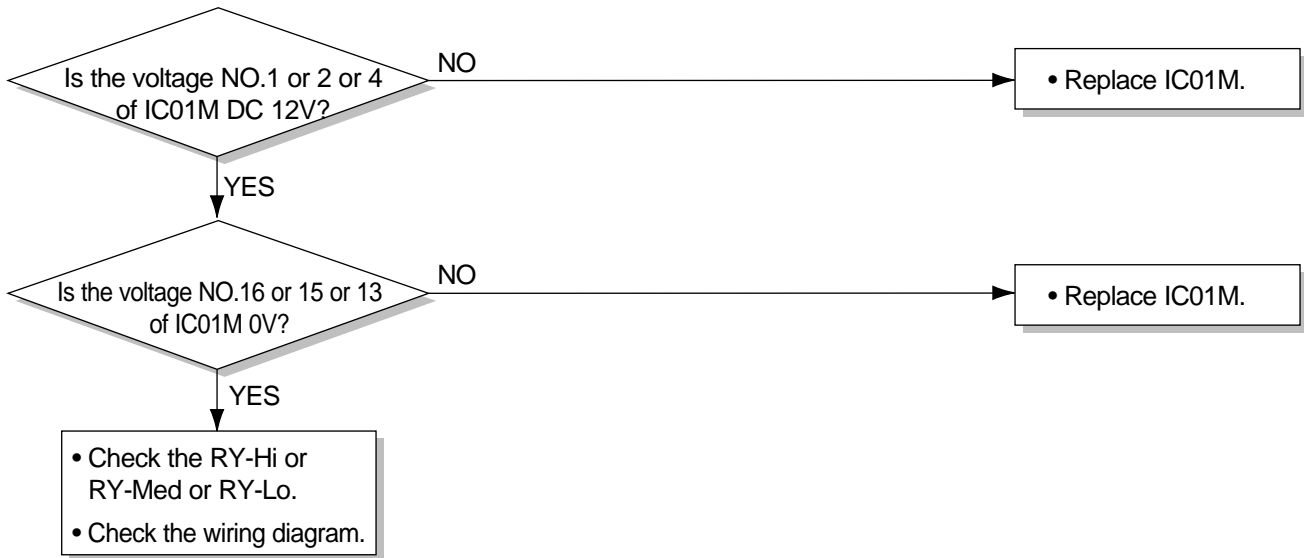

**Possible Trouble 5**

The function of Energy Saver does not operate.

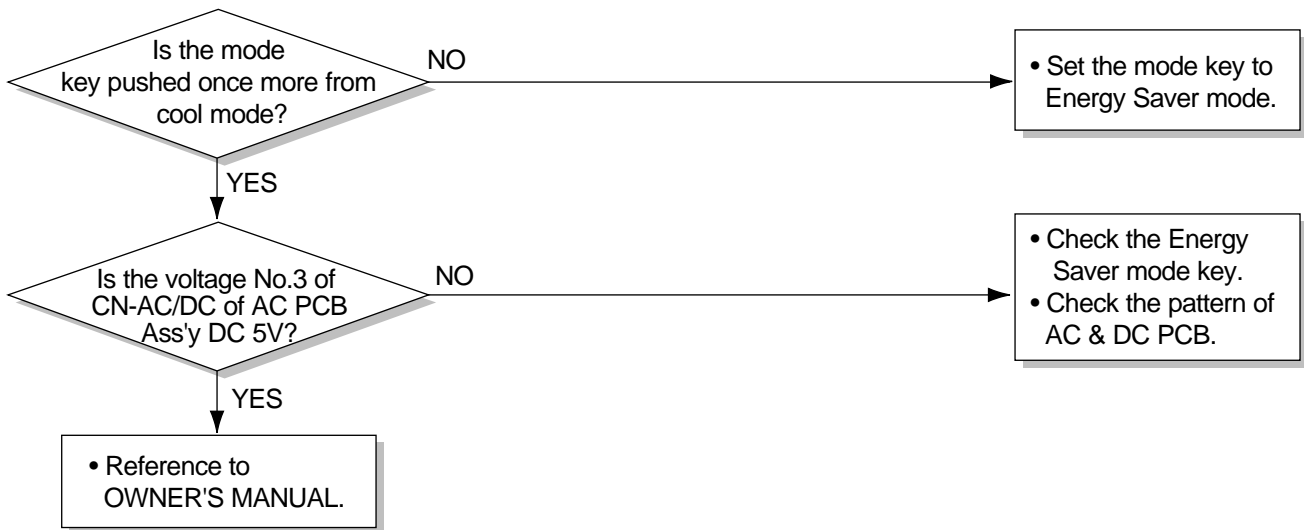

**Possible Trouble 6**

Remote controller does not operate.

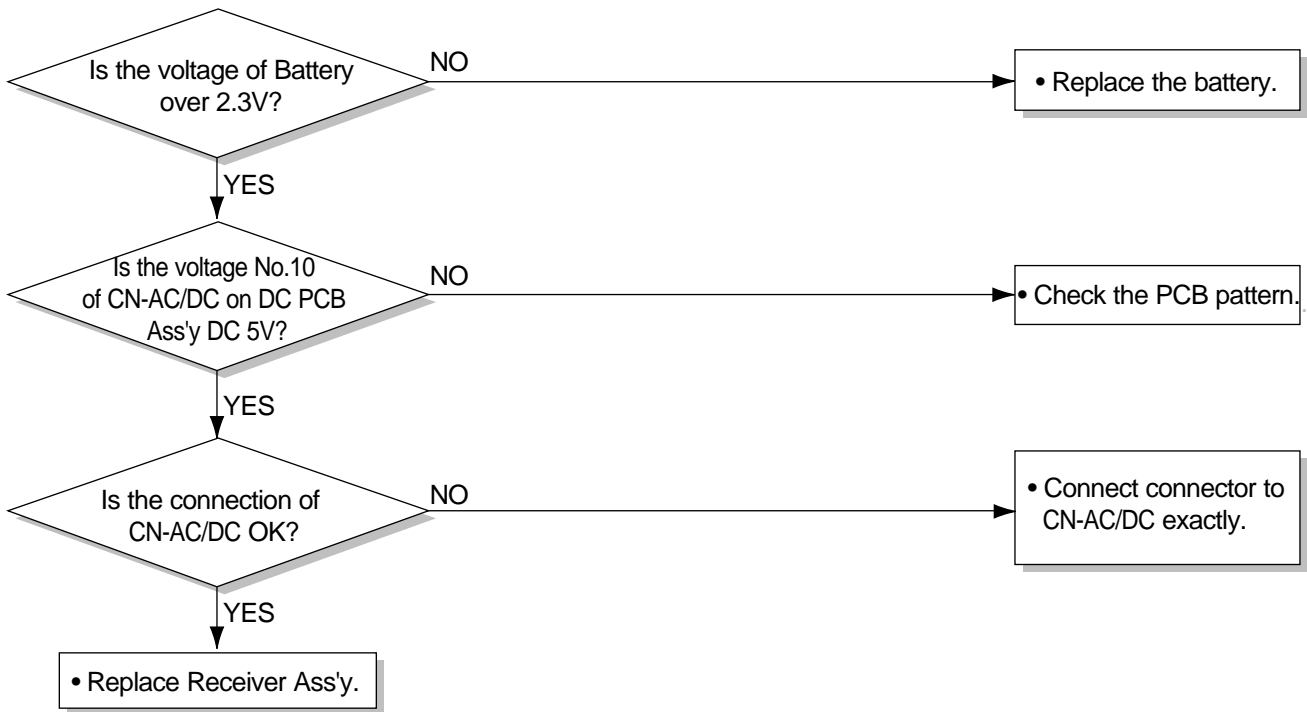

**Possible Trouble 7**

It displays abnormally on DC PCB Ass'y.

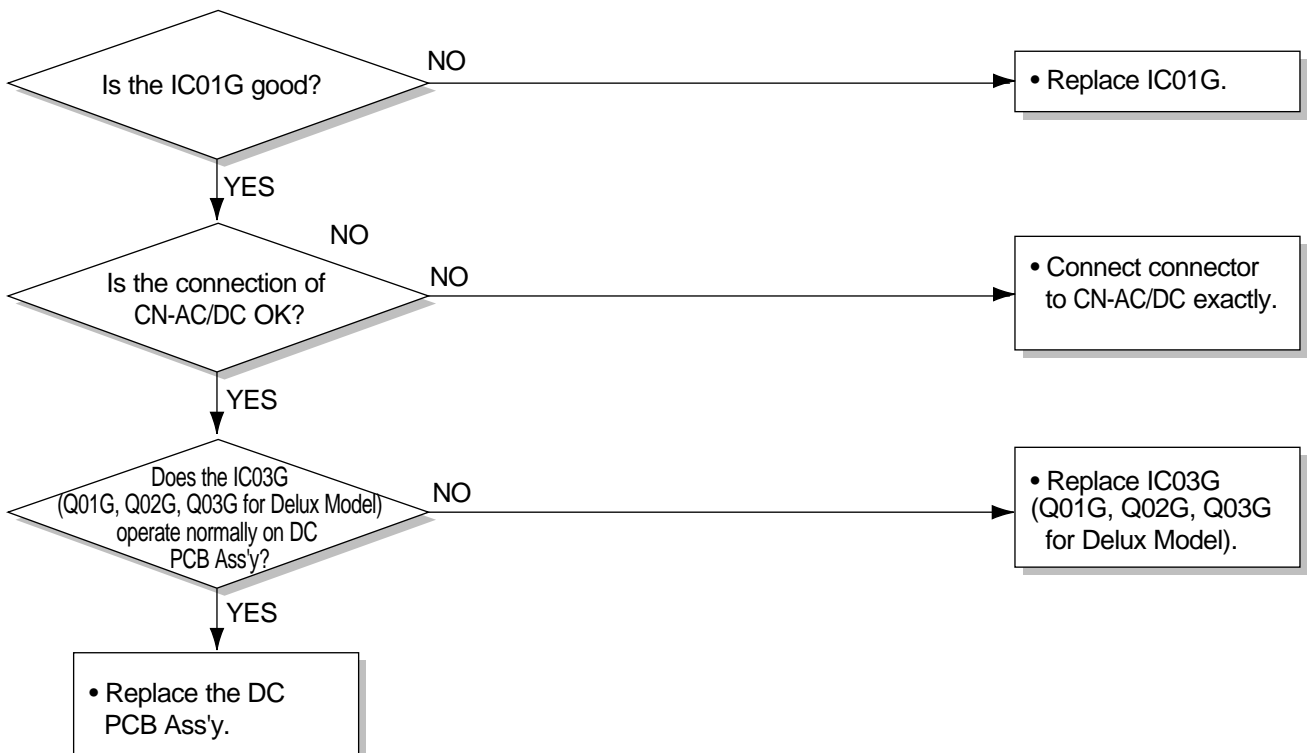

# Electric Parts

**Possible Trouble 1**

The unit does not operate.

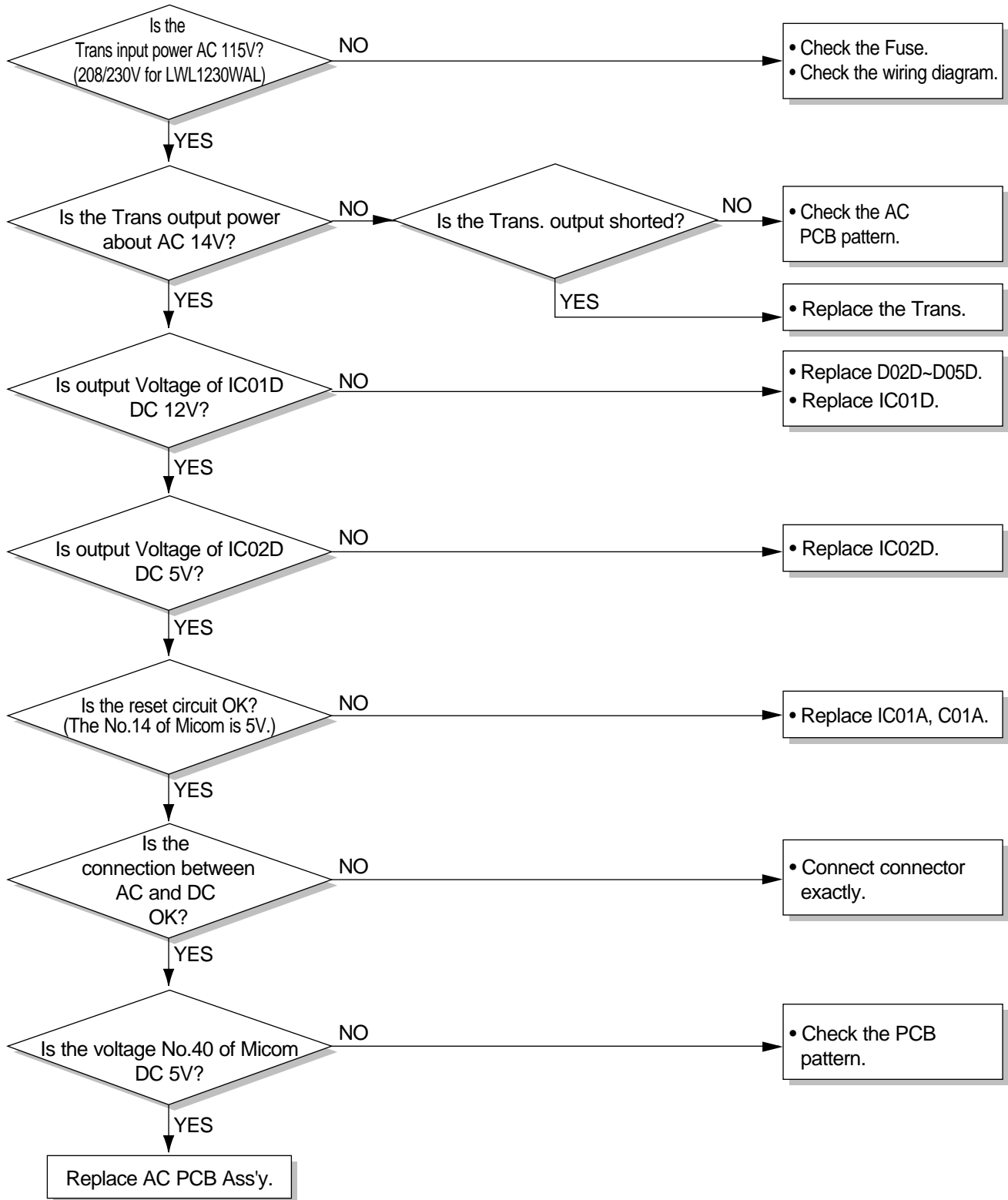

**Possible Trouble 2**

The compressor does not operate.

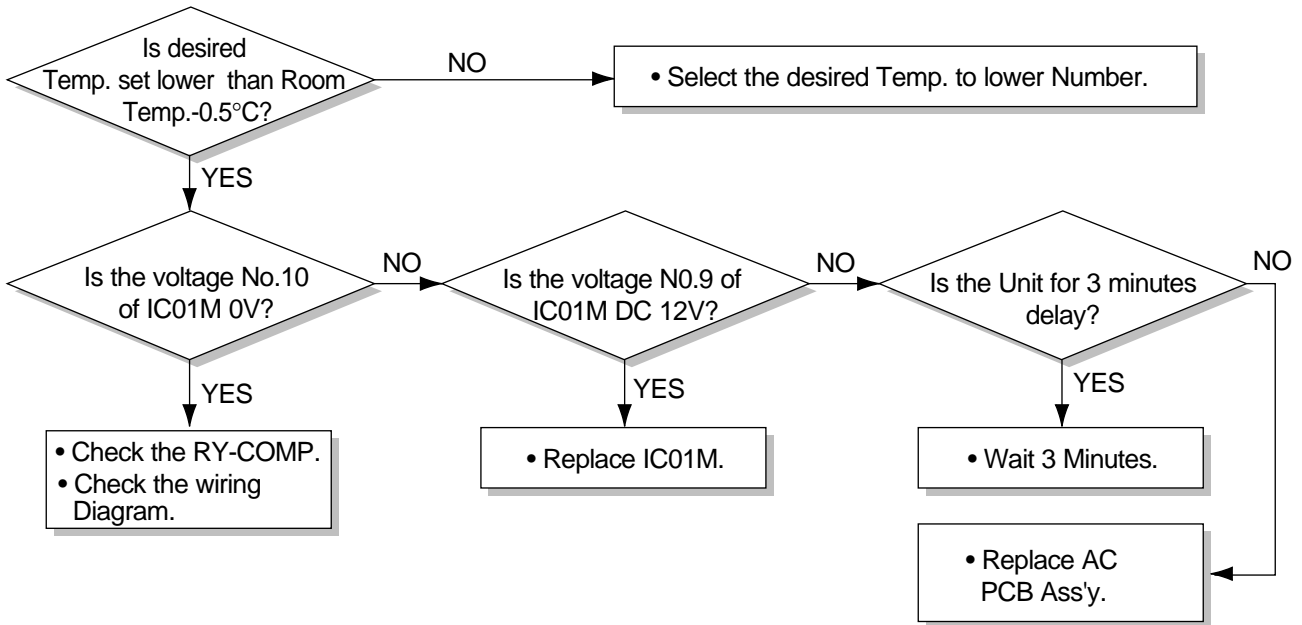

**Possible Trouble 3**

The compressor always operate.

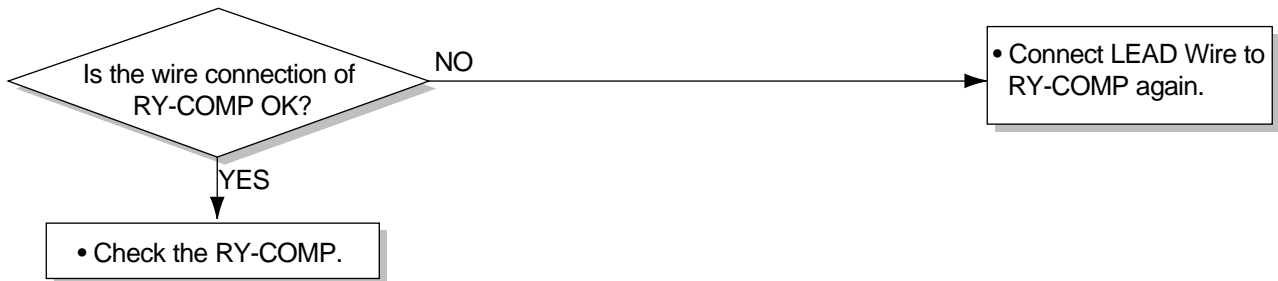

**Possible Trouble 4**

FAN does not operate.

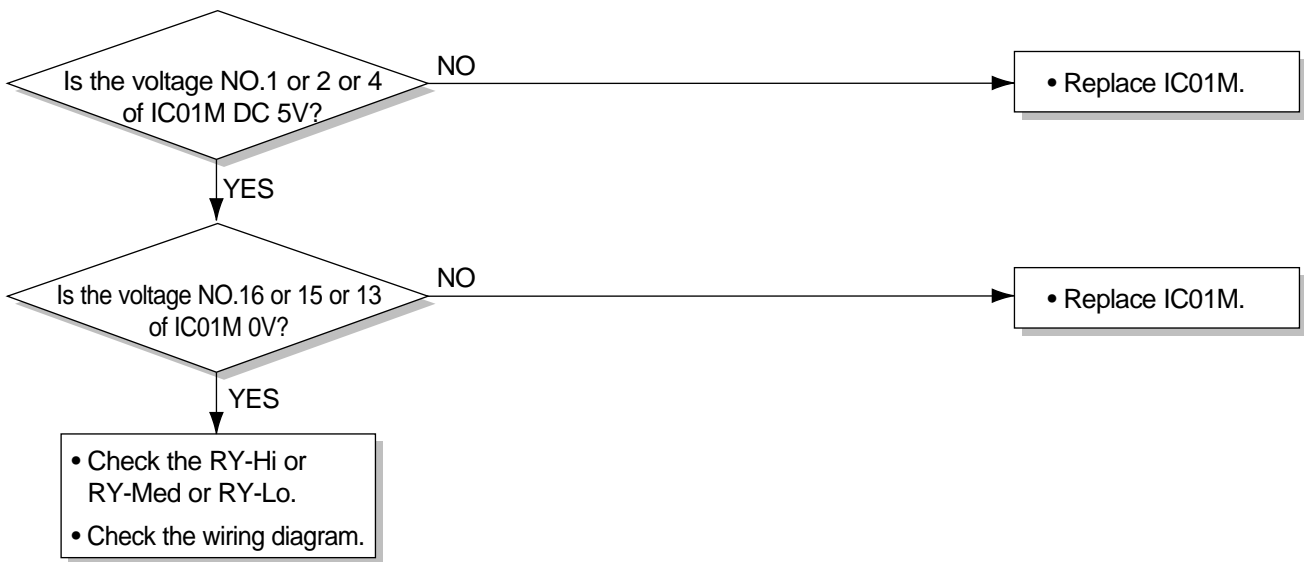

**Possible Trouble 5**

Remote controller does not operate.

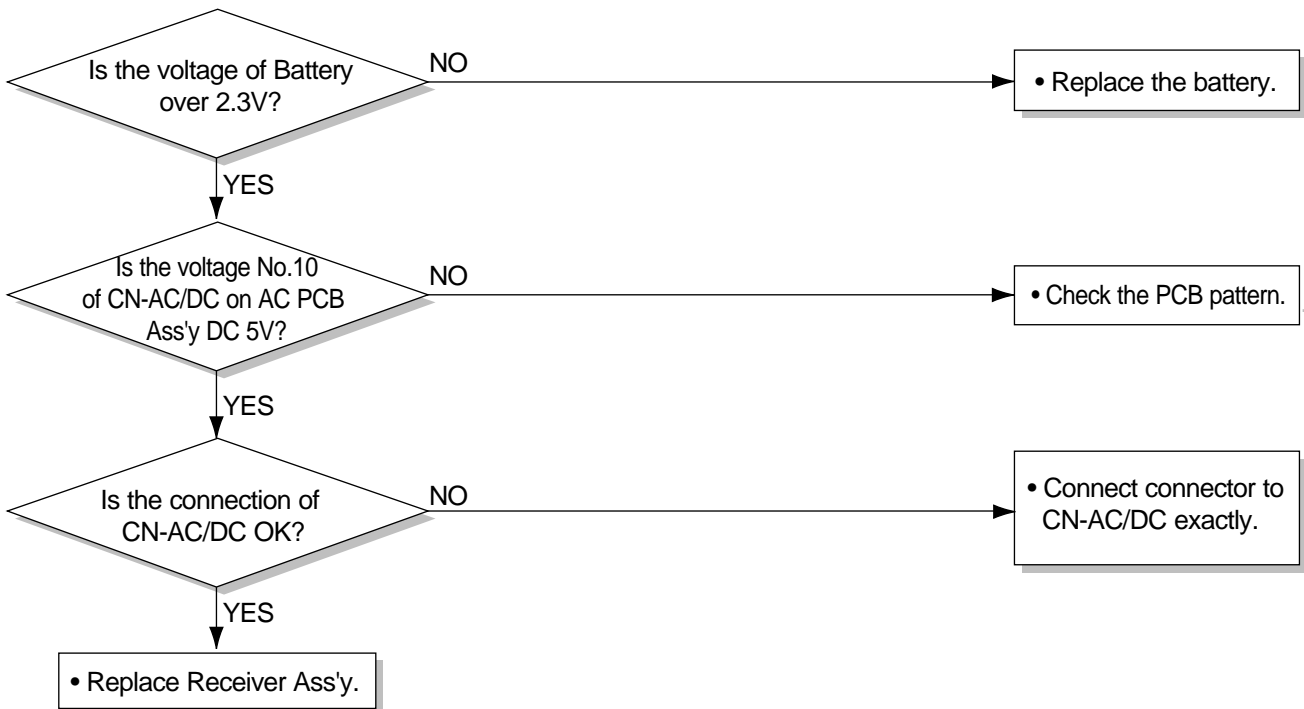

**Possible Trouble 6**

It displays abnormally on DC PCB Ass'y.

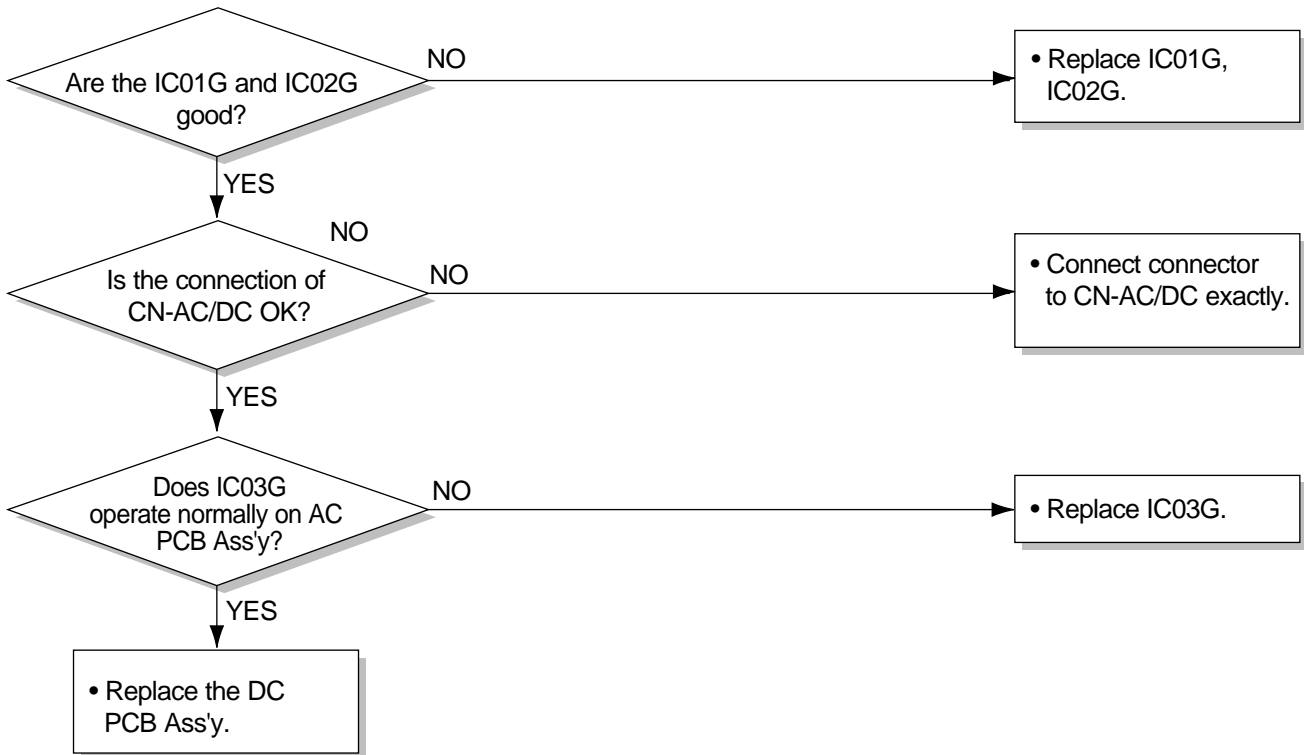



| COMPLAINT                                    | CAUSE   | REMEDY  |
|--|---|---|
| Fan motor will not run.                      | No power  | Check voltage at outlet. Correct if none.   |
|  | Power supply cord                               | Check voltage to Control Box. If none, check power supply cord. Replace cord if circuit is open.  |
|  | Wire disconnected or connection loose           | Connect wire. Refer to wiring diagram for terminal identification. Repair or replace loose terminal.  |
|  | Capacitor (Discharge capacitor before testing.) | Test capacitor.<br>Replace if not within $\pm 10\%$ of manufacturer's rating.<br>Replace if shorted, open, or damaged.  |
|  | Will not rotate                                 | Fan blade hitting shroud or blower wheel hitting scroll. Realign assembly.<br><br>Units using slinger ring for condenser fan must have $\frac{1}{4}$ to $\frac{5}{16}$ inch clearance to the base. If it hits the base, shim up the bottom of the fan motor with mounting screw(s).<br><br>Check fan motor bearings; if motor shaft will not rotate, replace the motor. |
| Fan motor runs intermittently                | Revolves on overload.                           | Check voltage. If not within limits, call an electrician.<br><br>Test capacitor.<br>Check bearings. Does the fan blade rotate freely?<br>If not, replace fan motor.<br><br>Pay attention to any change from high speed to low speed. If the speed does not change, replace the motor.   |
| Fan motor noise.                             | Fan   | If cracked, out of balance, or partially missing, replace it.   |
|  | Turbo   | If cracked, out of balance, or partially missing, replace it.   |
|  | Loose clamper                                   | Tighten it.   |
|  | Worn bearings                                   | If knocking sounds continue when running or loose, replace the motor. If the motor hums or noise appears to be internal while running, replace motor.   |
| Compressor will not run, but fan motor runs. | Voltage   | Check voltage.<br>If not within limits, call an electrician.  |
|  | Wiring  | Check the wire connections, if loose, repair or replace the terminal. If wires are off, refer to wiring diagram for identification, and replace. Check wire locations. If not per wiring diagram, correct.  |

| COMPLAINT                                    | CAUSE   | REMEDY  |
|--|---|---|
| Compressor will not run, but fan motor runs. | Thermistor  | Check the TEMP control. If not at the lowest number, set TEMP control to this setting and restart the unit. Check the continuity of the thermistor. Replace the thermistor if the circuit is open.  |
|  | Capacitor (Discharge capacitor before servicing.) | Check the capacitor. Replace if not within $\pm 10\%$ of manufacturers rating. Replace if shorted, open, or damaged.  |
|  | Compressor  | Check the compressor for open circuit or ground. If open or grounded, replace the compressor.   |
|  | Overload  | Check the compressor overload, if externally mounted. Replace if open. (If the compressor temperature is high, remove the overload, cool it, and retest.)   |
| Compressor cycles on overload.               | Voltage   | Check the voltage. If not within limits, call an electrician.   |
|  | Overload  | Check overload, if externally mounted. Replace if open. (If the compressor temperature is high, remove the overload, cool, and retest.)   |
| Compressor cycles on overload.               | Fan motor   | If not running, determine the cause. Replace if required.   |
|  | Condenser air flow restriction                    | Remove the cabinet. inspect the interior surface of the condenser; if restricted, clean carefully with a vacuum cleaner (do not damage fins) or brush. Clean the interior base before reassembling. |
|  | Condenser fins (damaged)                          | If condenser fins are closed over a large area on the coil surface, head pressures will increase, causing the compressor to overload. Straighten the fins or replace the coil.                      |
| Compressor cycles on overload.               | Capacitor   | Test capacitor.   |
|  | Wiring  | Check the terminals. If loose, repair or replace.   |
|  | Refrigerating system                              | Check the system for a restriction.   |
| Insufficient cooling or heating              | Air filter  | If restricted, clean or replace.  |
|  | Exhaust damper door                               | Close if open.  |
|  | Unit undersized                                   | Determine if the unit is properly sized for the area to be cooled.  |
| Excessive noise                              | Turbo or fan                                      | Check the set screw or clamp. If loose or missing, correct. If the turbo or fan is hitting air guide, rearrange the air handling parts.   |
|  | Copper tubing                                     | Remove the cabinet carefully and rearrange tubing not to contact cabinet, compressor, shroud, and barrier.  |

# Exploded View

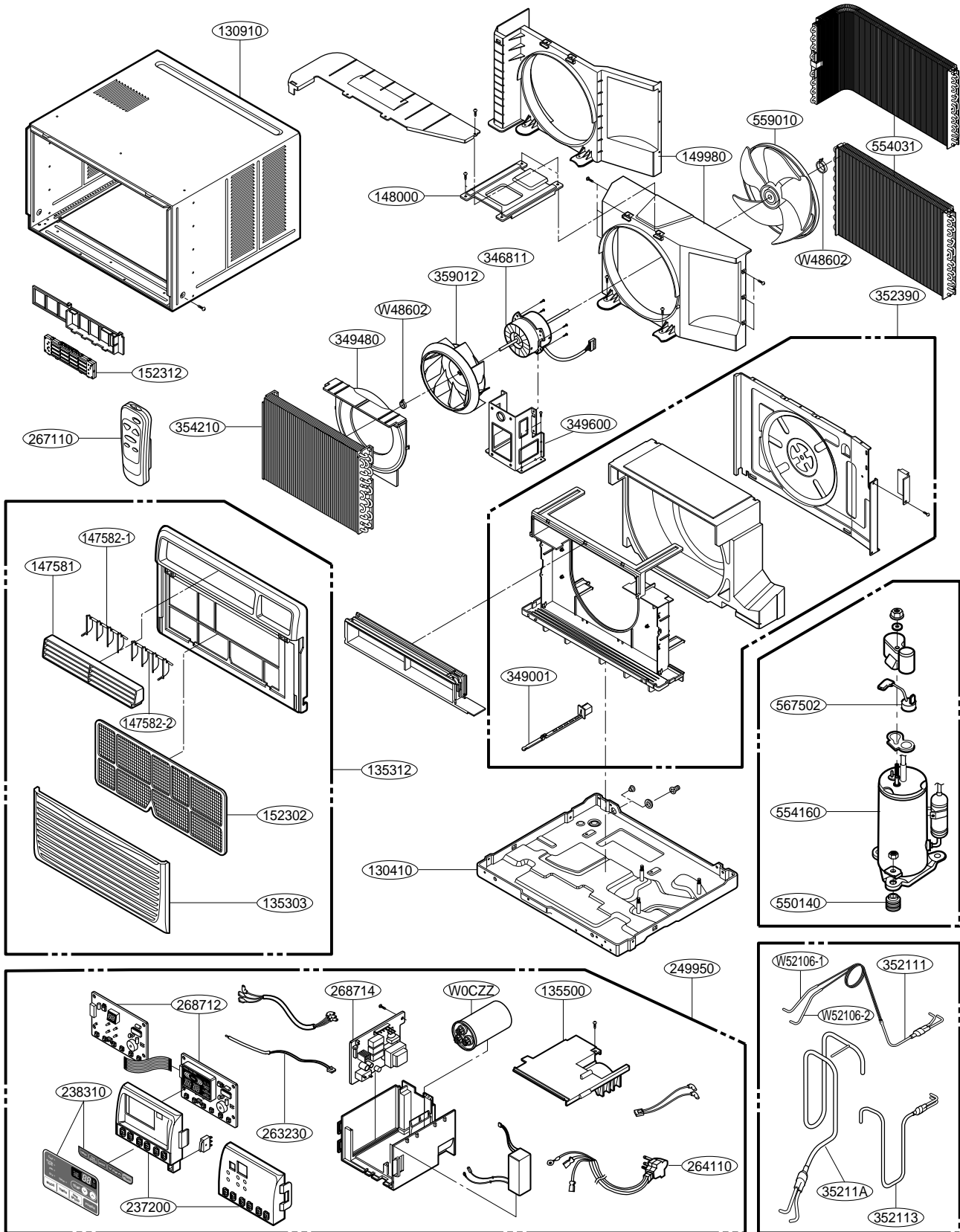

# Replacement Parts List

| LOCATION NO. | DESCRIPTION                     | PART NO.    |             |                   |             | REMARK |
|--------------|---------------------------------|-------------|-------------|-------------------|-------------|--------|
|              |                                 | HBLG1453E   | HBLG1803R   | L1804R<br>LW180CE | LW1400ER    |        |
| 130410       | BASE ASSEMBLY, WELD[SINGLE]     | 3041A20023B | 3041A20023V | 3041A20023V       | 3041A20023B | R      |
| 130910       | CABINET ASSEMBLY, SINGLE        | 3091AR6057J | 3091AR6057J | 3091AR6057J       | 3091AR6057J | R      |
| 135312       | GRILLE ASSEMBLY, FRONT(SINGLE)  | 3531A10201A | 3531A10201A | 3531A20095A       | 3531A20095A | R      |
| 135303       | GRILLE, INLET                   | 3530A10146A | 3530A10146A | 3530A10080A       | 3530A10080A | R      |
| 135500       | COVER                           | 3550A30122A | 3550A30122A | 3550A30122A       | 3550A30122A | R      |
| 147581       | LOUVER, HORIZONTAL              | 4758A30022A | 4758A30022A | 4758A30022A       | 4758A30022A | R      |
| 147582-1     | LOUVER, VERTICAL                | 4758A20042A | 4758A20042A | 4758A20042A       | 4758A20042A | R      |
| 147582-2     | LOUVER, VERTICAL                | 4758A20042B | 4758A20042B | 4758A20042B       | 4758A20042B | R      |
| 148000       | BRACE                           | 4800A20001A | 4800A20001A | 4800A20001A       | 4800A20001A | R      |
| 149980       | SHROUD                          | 4998A10013A | 4998A10026A | 4998A10026A       | 4998A10013A | R      |
| 152302       | FILTER ASSEMBLY, AIR CLEANER    | 5231A20008A | 5231A20008A | 5231A20008A       | 5231A20008A | R      |
| 237200       | PANEL, CONTROL                  | 3720A10112A | 3720A10112A | 3720A10112A       | 3720A10112A | R      |
| 249950       | CONTROL BOX ASSEMBLY, SINGLE    | 4995A20194Z | 4995A20194Y | 4995A20278L       | 4995A20194Z | R      |
| 268712       | PWB(PCB) ASSEMBLY, MAIN(AC)     | 6871A20167E | 6871A20167D | 6871A20167D       | 6871A20167E | R      |
| 238310       | ESCUTCHEON                      | 3831A10021F | 3831A10021F | 3831A10021M       | 3831A10021F | R      |
| 268714       | PWB(PCB) ASSEMBLY, MAIN(DC)     | 6871A20325A | 6871A20325A | 6871A20325A       | 6871A20325A | R      |
| 263230       | THERMISTOR ASSEMBLY             | 6323A20004E | 6323A20004E | 6323A20004E       | 6323A20004E | R      |
| 264110       | POWER CORD ASSEMBLY             | 6411A20011J | 6411A20011K | 6411A20011K       | 6411A20011J | R      |
| 346811       | MOTOR ASSEMBLY, SINGLE          | 4681AR6033X | 4681A20081A | 4681A20081A       | 4681AR6033X | R      |
| 349001       | VENTILATION DAMPER              | 4900A20004A | 4900A20004A | 4900A20004A       | 4900A20004A | R      |
| 349480       | ORIFICE                         | 4948A30008A | 4948A30008A | 4948A30008A       | 4948A30008A | R      |
| 349600       | MOUNT, MOTOR                    | 4960AR1596A | 4960AR1596A | 4960AR1596A       | 4960AR1596A | R      |
| 352111       | TUBE, CAPILLARY BEND            | 5210A30646A | 5210A20492R | 5210A20492R       | 5210A30646A | R      |
| 352113       | TUBE ASSEMBLY, DISCHARGE SINGLE | 5211A30066R | 5211A30066N | 5211A30066N       | 5211A30066R | R      |
| W52106-1     | TUBE, FORMED                    | 5210A21099L | 5210A21099L | 5210A21099L       | 5210A21099L | R      |
| W52106-2     | TUBE, FORMED                    | 5210A21099M | 5210A21099M | 5210A21099M       | 5210A21099M | R      |
| 35211A       | TUBE ASSEMBLY, SUCTION(OUTDOOR) | 5211A20441G | 5211A20441E | 5211A20441E       | 5211A20441G | R      |
| 352390       | AIR GUIDE ASSEMBLY              | 5239A20002A | 5239A20002A | 5239A20002A       | 5239A20002A | R      |
| 354210       | EVAPORATOR ASSEMBLY, FIRST      | 5421A20091E | 5421A20091E | 5421A20091E       | 5421A20091E | R      |
| 550140       | ANTI-VIBRATION BUSH             | 4H00982C    | 4H00982C    | 4H00982C          | 4H00982C    | R      |
| 554031       | CONDENSER ASSEMBLY, FIRST       | 5403A20062B | 5403A20112B | 5403A20112B       | 5403A20062B | R      |
| 554160       | COMPRESSOR SET                  | 2520UMTC2BA | 2520UMGK2AA | 2520UMGK2AA       | 2520UMTC2BA | R      |
| 559010       | FAN ASSEMBLY, AXIAL             | 5901A20010A | 5900AR1330A | 5900AR1508A       | 5901A20010A | R      |
| 359012       | FAN ASSEMBLY, TURBO             | 5901A20009A | 5901A20009A | 5901A20009A       | 5901A20009A | R      |
| 267110       | REMOTE CONTROLLER ASSEMBLY      | 6711A20056S | 6711A90019C | 6711A20034G       | 6711A20056S | R      |
| W48602       | CLAMP, SPRING                   | 3H02932C    | 3H02932C    | 3H02932C          | 3H02932C    | R      |
| W0CZZ        | CAPACITOR, DRAWING              | 0CZZA20001L | 6120AR2194F | 6120AR2194F       | 0CZZA20001L | R      |





